



## HVAC - Sensor and Actuator Technologies

### Sensor and Actuator Definition

- **Sensors measure**
  - Converts nonelectrical signals to an electrical signal (input)
    - Temperature, pressure, light, position, speed, levels, humidity, etc
    - Analog and Digital
- **Actuators provide movement**
  - Converts electrical signals into an action or movement (output)
    - Motors, solenoids



### Sense – Compare - Correct

- Before A/C Service



← 3 →

### Sense – Compare - Correct

- During A/C Service

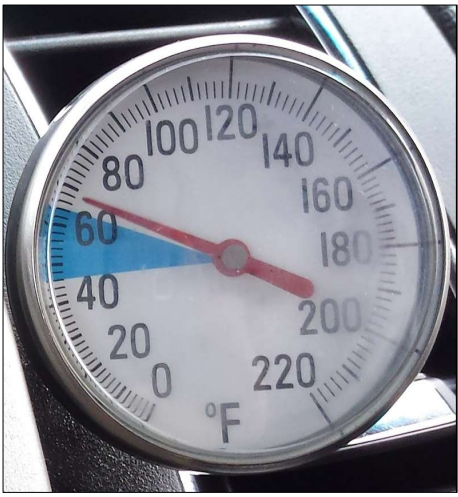

- After A/C Service



← 4 →

## HVAC Sensor Overview

- **Engine Compartment Sensors**
  - Ambient Air temperature
    - OAT (Outside Air Temp)
  - Air Quality Exterior
  - A/C pressure sensor (transducer)
- **Electronic VD Compressor**
  - RPM sensor
    - A/C Clutch vs engine speed
  - Refrigerant Flow (volume) sensor
    - More precise compressor control
- **Passenger Compartment Sensors**
  - Temperature - NTC design
    - Fresh air inlet duct
    - Dash panel/footwell
    - Evaporator
    - Air Quality-Interior CO<sub>2</sub>
  - Sun load Sensor (Photodiode)
    - Solar load sensor
  - Humidity/Rain
    - Capacitance



← 5 →

## Snowflake Indicator – WHY?

- **NOT a malfunction!**
  - Algorithm provides driver warning
- **Frost/Icy Road Conditions**
  - Temperatures are low enough
    - 40°F (4°C)
  - Indicator light color status
    - Amber/Red as it gets colder
  - Chime (audible)

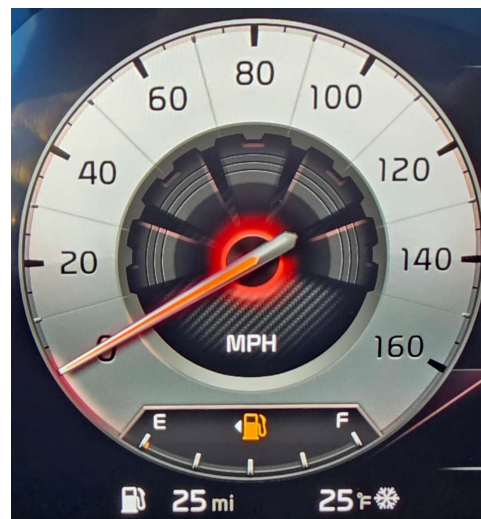

← 6 →



## HVAC - Fuzzy Control Logic

- **Input Variables**
  - Passenger cabin temperature
    - Actual vs. Setpoint
    - Errors
  - Humidity
  - Outdoor air temperature (OAT)
  - Solar Load
  - CO<sup>2</sup> levels
    - Air Quality
- **Fuzzification**
  - Data converted to fuzzy logic
    - Slightly warm
    - Very cold
- **Rules**
  - If “THIS” then “THAT”
    - If temperature is too HOT
    - With Humidity High
      - **THEN reduce fan speed to Medium**
        - Fan speed Fast = 70%
        - Fan speed Medium = 40%
        - Fan speed Low = 20%



← 7 →

## Defuzzification

- **Precise control for Actuators**
  - Heater control valves, solenoids
  - A/C compressor speeds
  - Blower motor speed
  - Blend and mode control doors
  - Recirculation control door
- **Vehicle Benefits**
  - Enhanced comfort
  - Quicker response
    - Less over/undershoot
  - Adaptability
    - Driver and vehicle conditions
  - Integration
    - E/V thermal management
    - Cabin climate control
  - Energy efficiency
    - A/C compressor optimization



← 8 →

# System Functional Example



Automatic transmission assembly transmission internal mode switch

Engine control module (ECM)



Input A/C EVAP temperature sensor

HVAC module

Body control module (BCM)



# 2018 Chevy Malibu – HVAC Logic

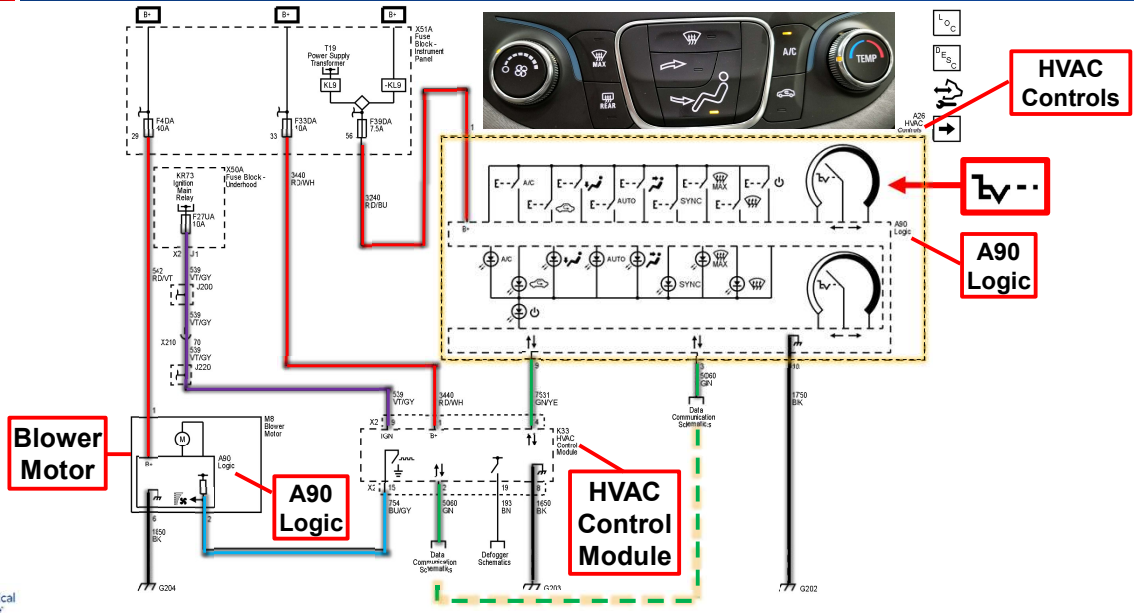

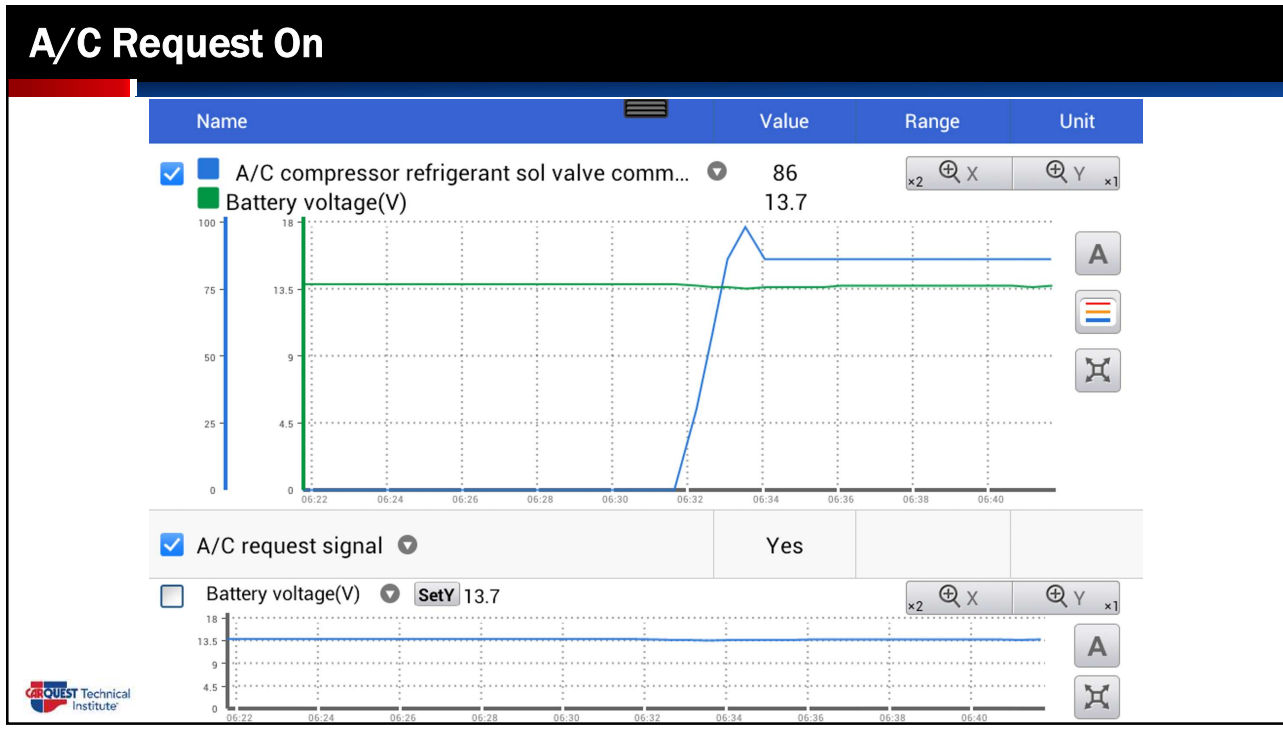

### Is the A/C On ?

Name	Value	Range	Unit
<input type="checkbox"/> Evaporator temperature ▼	37.4	-40.00.. .419.00	°F
<input type="checkbox"/> Outside temperature ▼	95	-31.00.. .212.00	°F
<input type="checkbox"/> Outside temperature (display value) ▼	73.4	-40.00.. .194.00	°F
<input type="checkbox"/> In car temperature ▼	78.8	32.00...491.00	°F
<input type="checkbox"/> Engine coolant temperature ▼	197.6	-40.00.. .491.00	°F
<input type="checkbox"/> Solar sensor passenger ▼	0	0...100000000	W/m2
<input type="checkbox"/> Solar sensor driver ▼	0	0...100000000	W/m2
<input type="checkbox"/> Driver set temperature ▼	60.8	32.00...491.00	°F
<input type="checkbox"/> Passengers set temperature ▼	60.8	32.00...491.00	°F

← 13 →

### Are We getting Cold?

Name	Value	Range	Unit
<input type="checkbox"/> A/C recirculating servo position status ▼	-----		
<input type="checkbox"/> A/C status ▼	ON		
<input type="checkbox"/> Blower Motor Speed ▼	86.66	[0...100]	%
<input type="checkbox"/> Diagnostic Trouble Codes ▼	0	[0...20]	
<input type="checkbox"/> ECU operating states ▼	Default		
<input type="checkbox"/> Evaporator Temperature ▼	82.4	[-40.00.. .212.00]	°F
<input type="checkbox"/> Front Blower Relay ▼	Off		
<input type="checkbox"/> Ignition Key Status ▼	Key in Run		
<input type="checkbox"/> Interior Temperature Sensor ▼	84.2	[-40.00.. .199.40]	°F

← 14 →

## Ambient Temperature Sensor

- Location
  - Front of condenser
- Description – Sensor Output
  - 2 wire NTC thermistor design
    - Cold = High Resistance
    - Warm = Lower resistance
  - Used for:
    - Discharge temperature control
    - Temperature regulation door control
    - Blower motor level control
    - Mix (blend) mode and humidity control
    - A/C compressor deactivation (cold conditions)

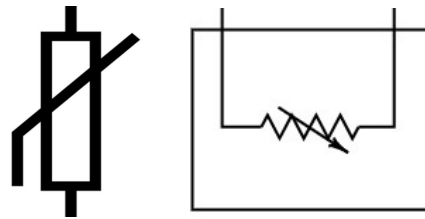
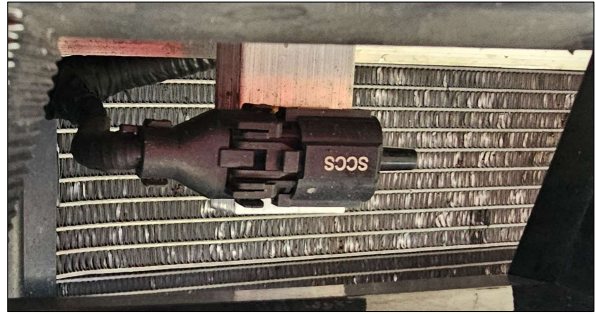

Symbols



## Ambient Temperature Sensor – Kia Specifications

- Service Information

Ambient Temperature °C/(F)		Resistance Between Terminals 1 and 2 (KΩ)
<b>COLD</b>	-30 (-22)	480.41
	-20 (-4)	271.21
<b>WARM</b>	-10 (14)	158.18
	0 (32)	95.10
	10 (50)	58.50
<b>HOT</b>	20 (68)	37.32
	30 (86)	24.26
	40 (104)	16.13
	50 (122)	10.95



# Ambient Temperature Sensor – Chevy Bolt Specifications

Temperature °C/(F)	(KΩ)	MIN (KΩ)	MAX (KΩ)	
-40	-40	169.4	181.19	
-30	-22	88.74	94.47	
-20	-4	48.58	50.02	
-10	14	27.67	28.44	
0	32	16.33	15.92	
10	50	9.95	9.71	
20	<b>68</b>	<b>6.24</b>	<b>6.1</b>	<b>6.38</b>
30	86	4.02	3.94	4.11
40	104	2.66	2.61	2.71
50	122	1.8	1.73	1.87
60	140	1.24	1.2	1.29



# Ambient Air Temp Sensor – Communication Logic

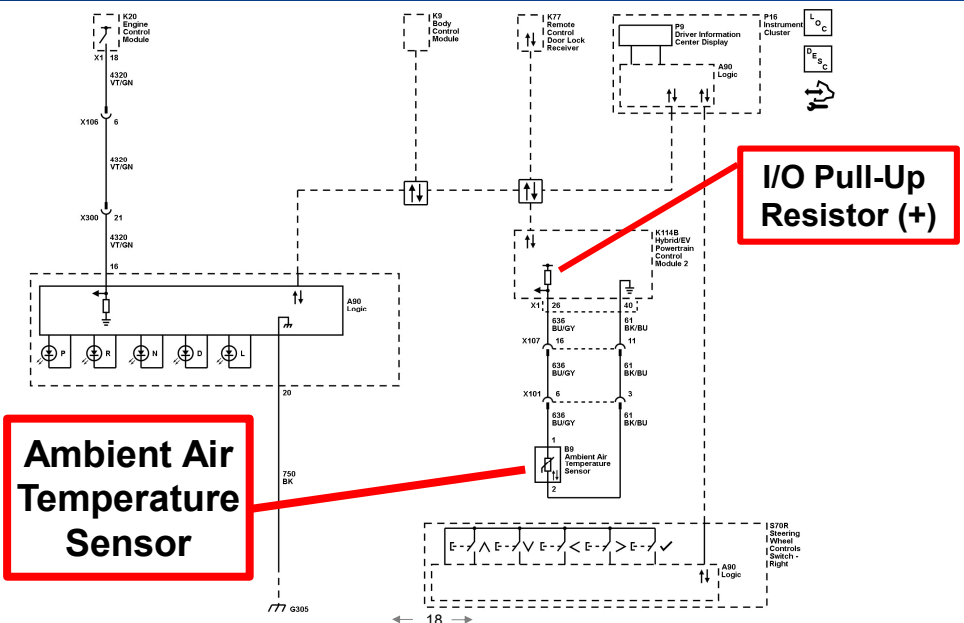

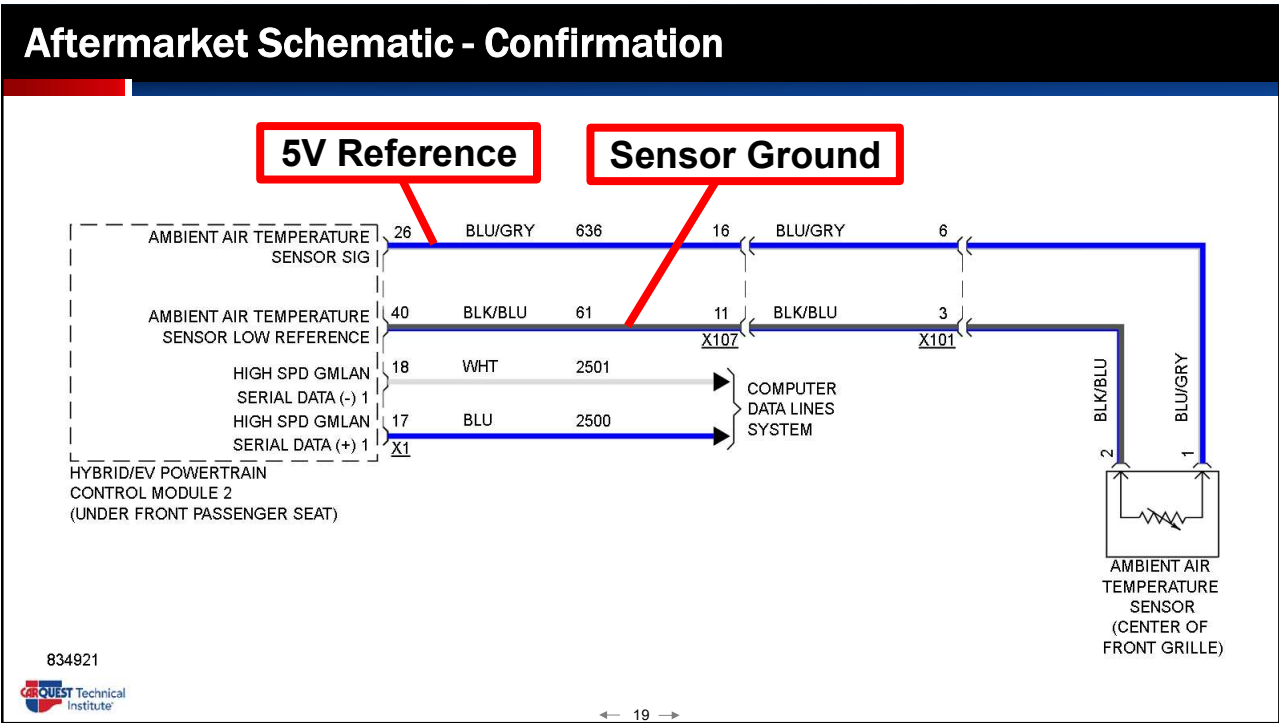

### ADAS and HVAC – Ford Bronco Example

- AAT Sensor Location/Placement
  - Beneath side view mirror
  - Away from the elements
- Systems
  - Dual Automatic Temp control (DATC)
  - Electronic Manual Temp control (EMTC)
- Parking Aid Systems (**Europe ONLY**)
  - Speed of sounds changes
    - Faster when warm
    - Slower when cold
  - Ultrasonic sensor reads proximity to objects more accurately

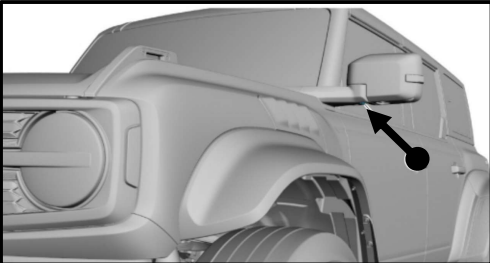
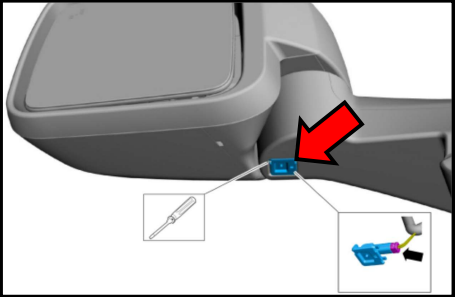



Carquest Technical Institute

← 20 →

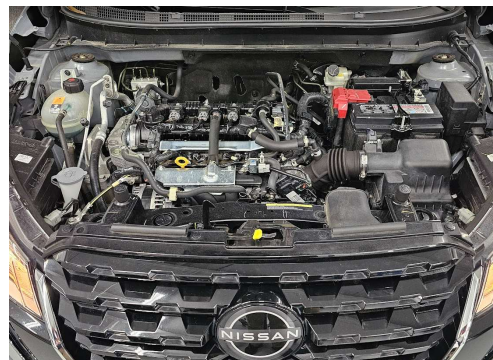

### 2022 Nissan Kicks – Ambient Air Temp Sensor



### 2022 Nissan Kicks - Scan Tool View - TOPDON

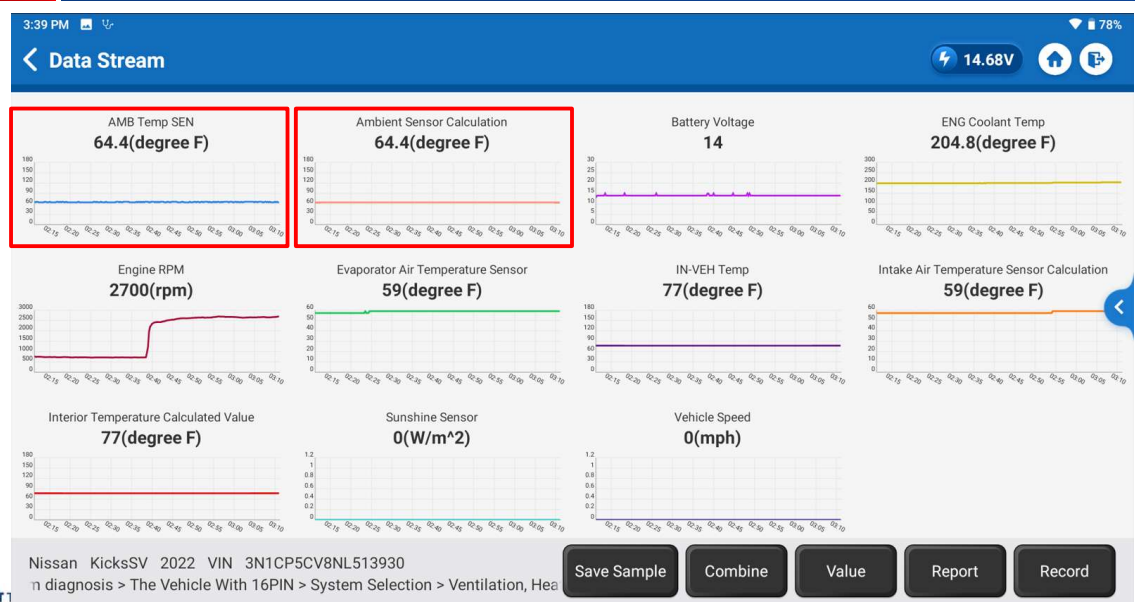

## Refrigerant Pressure Sensor – Nissan Example

- Converts high pressure into voltage
  - Three wire pressure sensor
    - Transducer
  - Read by Engine Control Module (ECM)
  - ECM controls
    - Cooling system protection
    - Idle speed
- Low Pressure = Low Voltage (0) V
- High Pressure = High Voltage (5) V

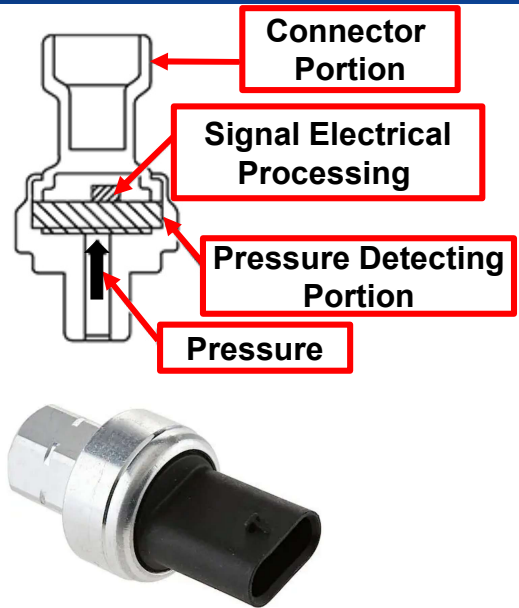

## 2022 Lexus UX 250h - HEV

- Connections @ Pressure Transducer



- DMM Measurements



A/C OFF



A/C ON



### 2017 Kia Cadenza – Scan Tool View – A/C Off

Kia V6.00

Kia > Automatic selection > Pre-Scan > ENG (Engine) > Live data

Name	Value	Unit
<input type="checkbox"/> AC Request to ECU	Off	
<input type="checkbox"/> A/C Compressor on by ECU	Off	
<input type="checkbox"/> A/C On condition	Off	
<input checked="" type="checkbox"/> A/C Pressure (psi)	164	
<input checked="" type="checkbox"/> A/C Pressure voltage (V)	2	

Graph 1: A/C Pressure (psi) vs Time (05:49-05:58). Y-axis: 0, 55.5, 111, 166.5, 222. Value: 164.

Graph 2: A/C Pressure voltage (V) vs Time (05:49-05:58). Y-axis: 0, 0.75, 1.5, 2.25, 3. Value: 2.

← 27 →

### 2017 Kia Cadenza – Scan Tool View - A/C On

Kia V6.00

Kia > Automatic selection > Pre-Scan > ENG (Engine) > Live data

Name	Value	Unit
<input type="checkbox"/> AC Request to ECU	On	
<input type="checkbox"/> A/C Compressor on by ECU	On	
<input type="checkbox"/> A/C On condition	On	
<input checked="" type="checkbox"/> A/C Pressure (psi)	192	
<input checked="" type="checkbox"/> A/C Pressure voltage (V)	2.2	

Graph 1: A/C Pressure (psi) vs Time (06:10-06:19). Y-axis: 0, 55.5, 111, 166.5, 222. Value: 192.

Graph 2: A/C Pressure voltage (V) vs Time (06:10-06:19). Y-axis: 0, 0.75, 1.5, 2.25, 3. Value: 2.2.

← 28 →

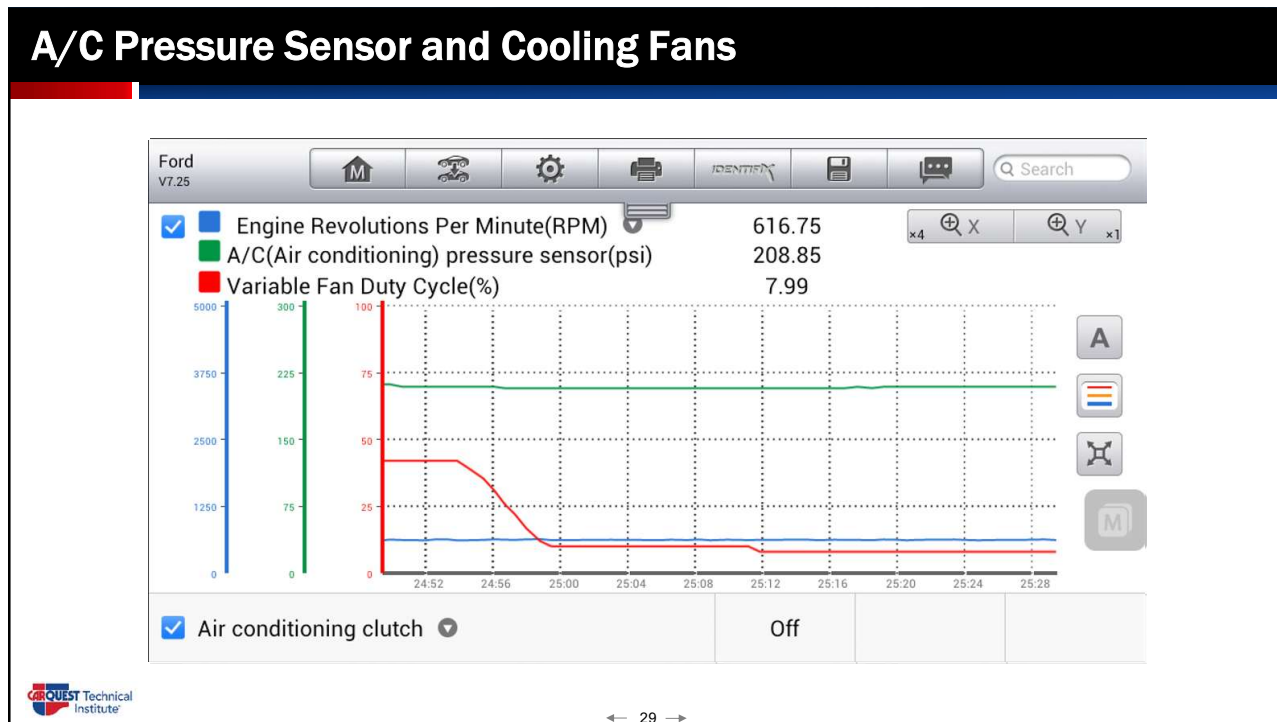

### 2019 Lexus IS-300

- **A/C Lock Sensor**
  - Detects if compressor is locking
  - Engine/Compressor- RPM deviation
    - Sends AC pulley speed signal to A/C Amplifier
- **Trouble Areas**
  - Magnetic Clutch Assembly
  - A/C Compressor
  - Harness or connector
  - Air Conditioning Amplifier

- **DTC B1422/22C**
- **Compressor Lock Sensor Circuit**
  - SEE Service Information
    - Engine running
    - Blower switch: Low
    - A/C Switch: On
  - Use Scope to validate signal

← 30 →

## Wiring Diagram

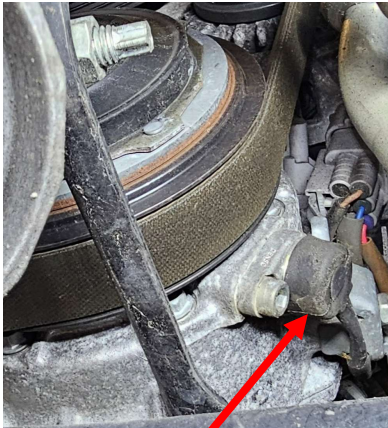

**A/C Lock Sensor**

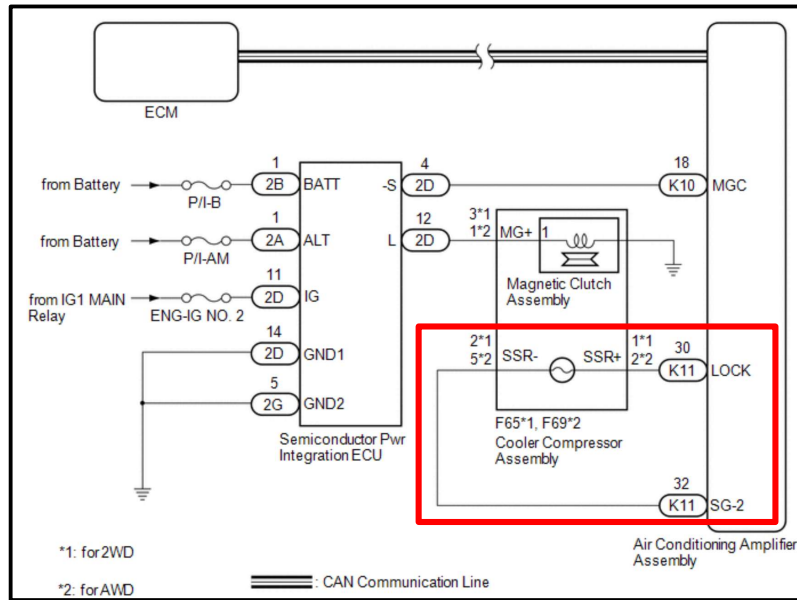

## A/C Evaporator Temperature

### NTC Design

- High resistance when cold
- Low resistance when hot



### Evaporator Cleaning

- Possible contamination

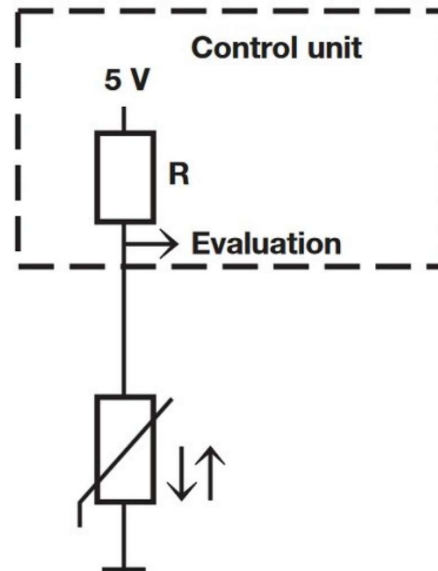

# Scan Tool View

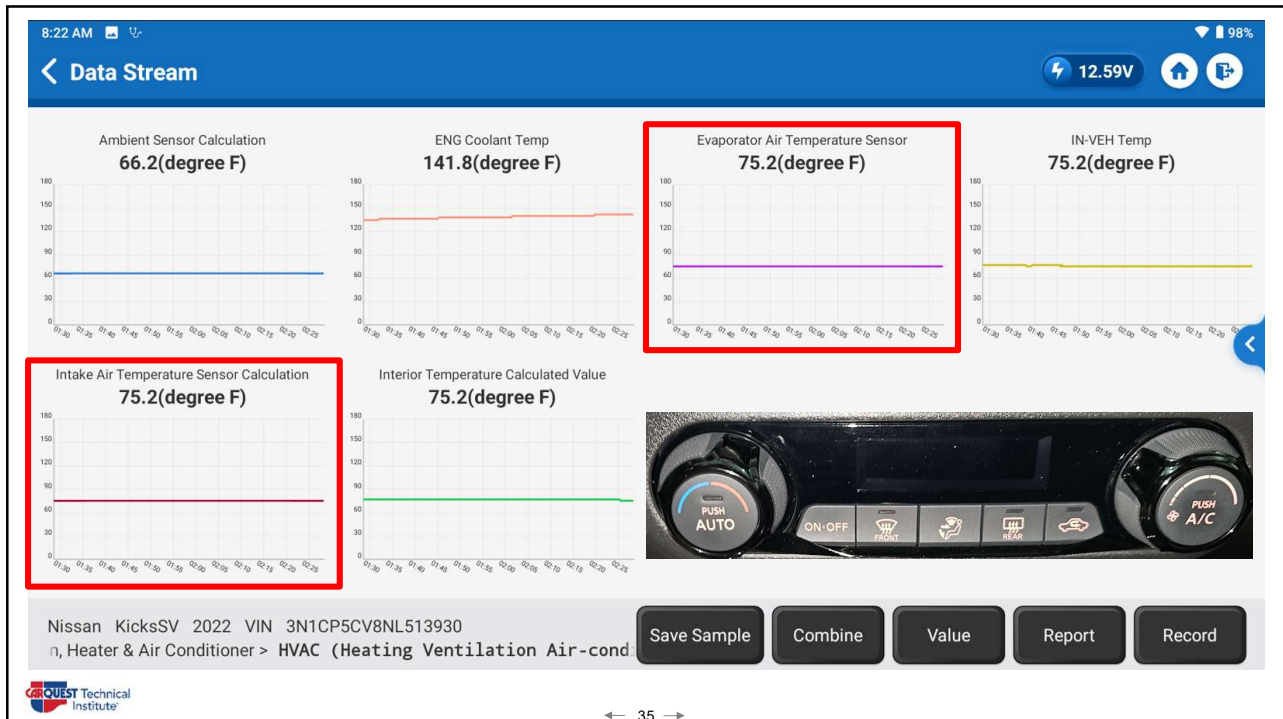
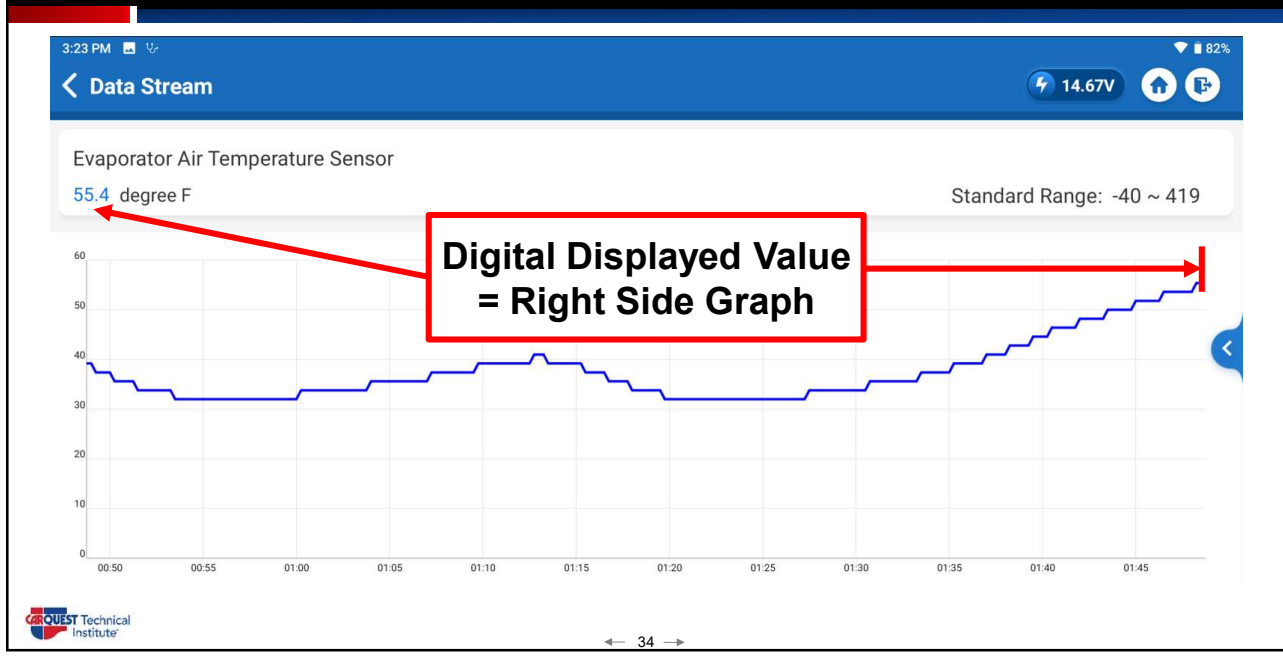

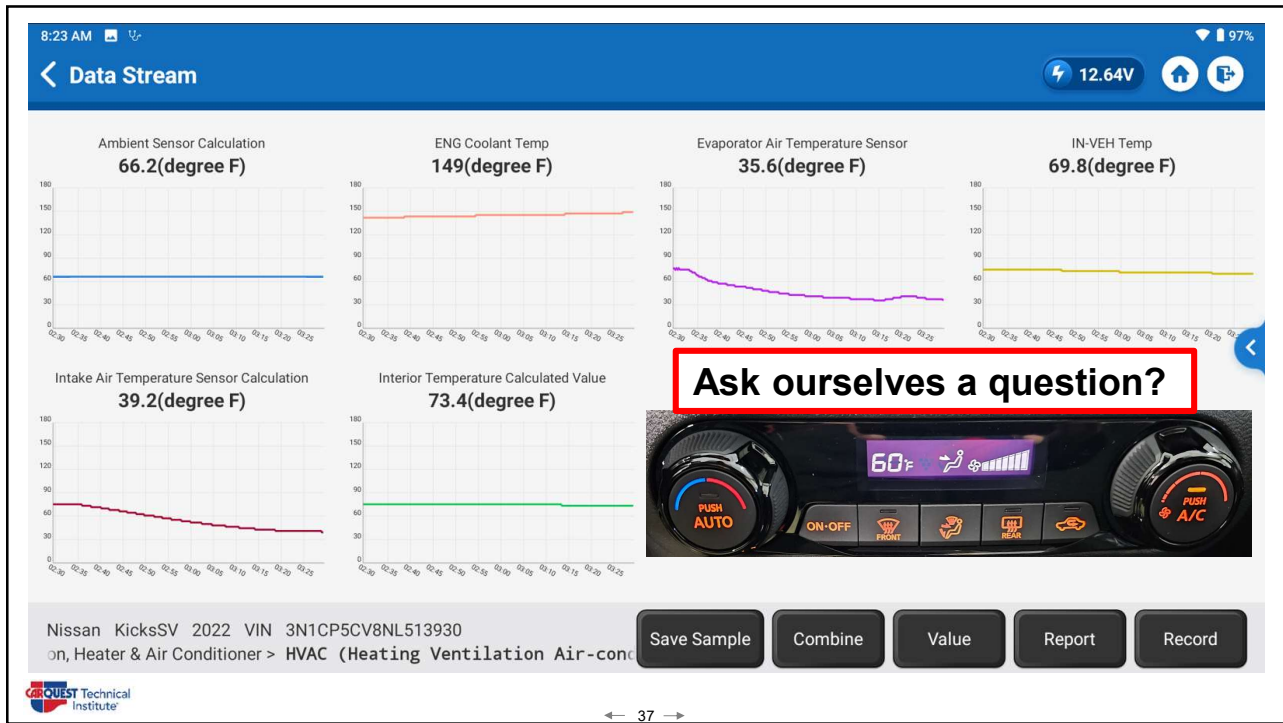
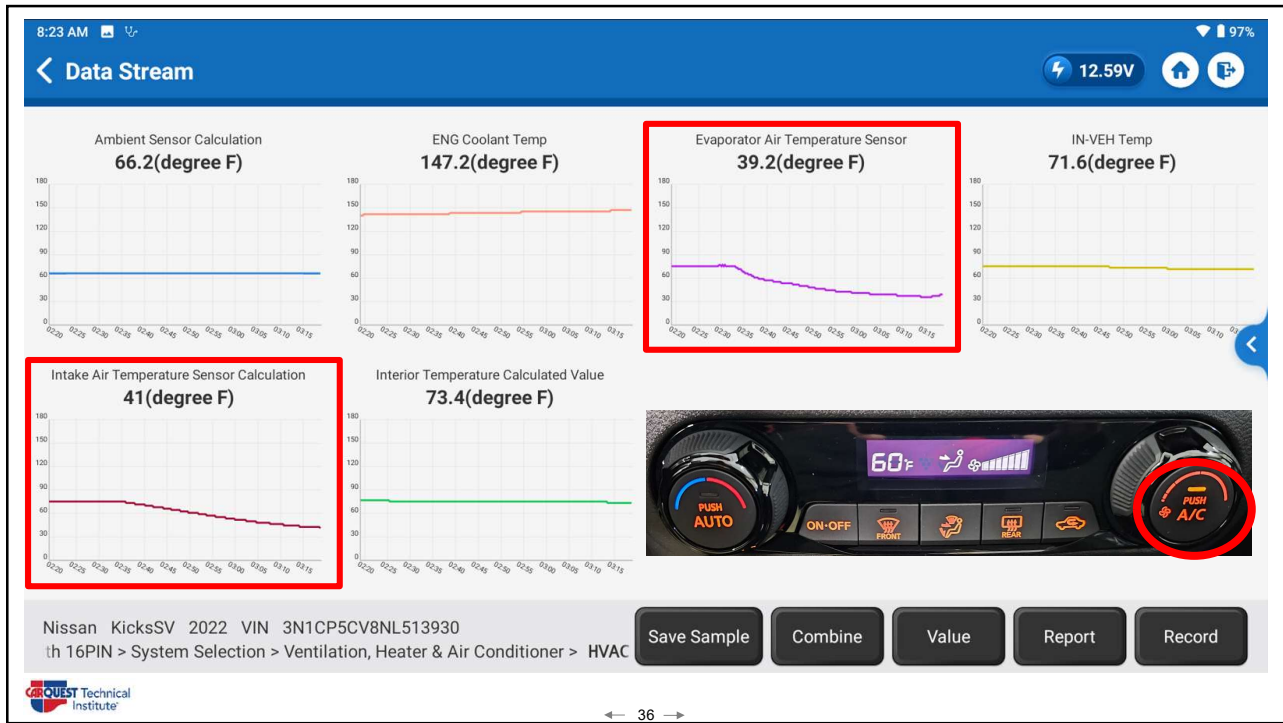

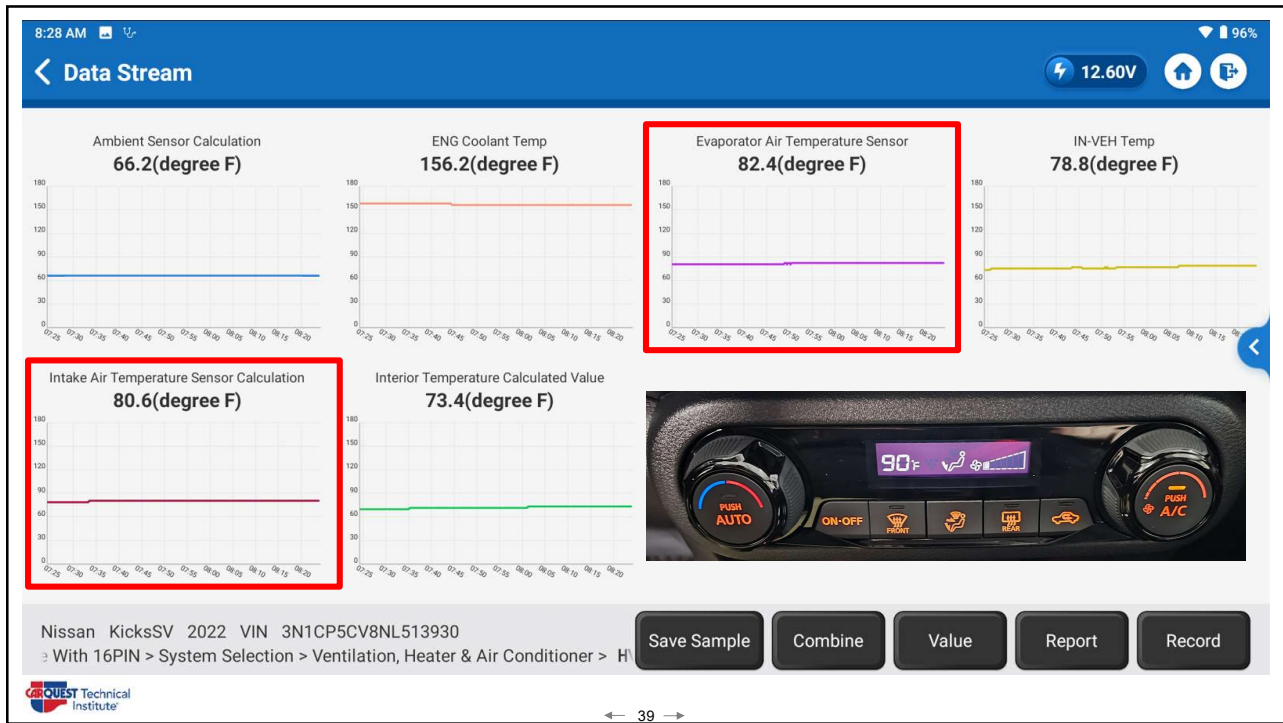
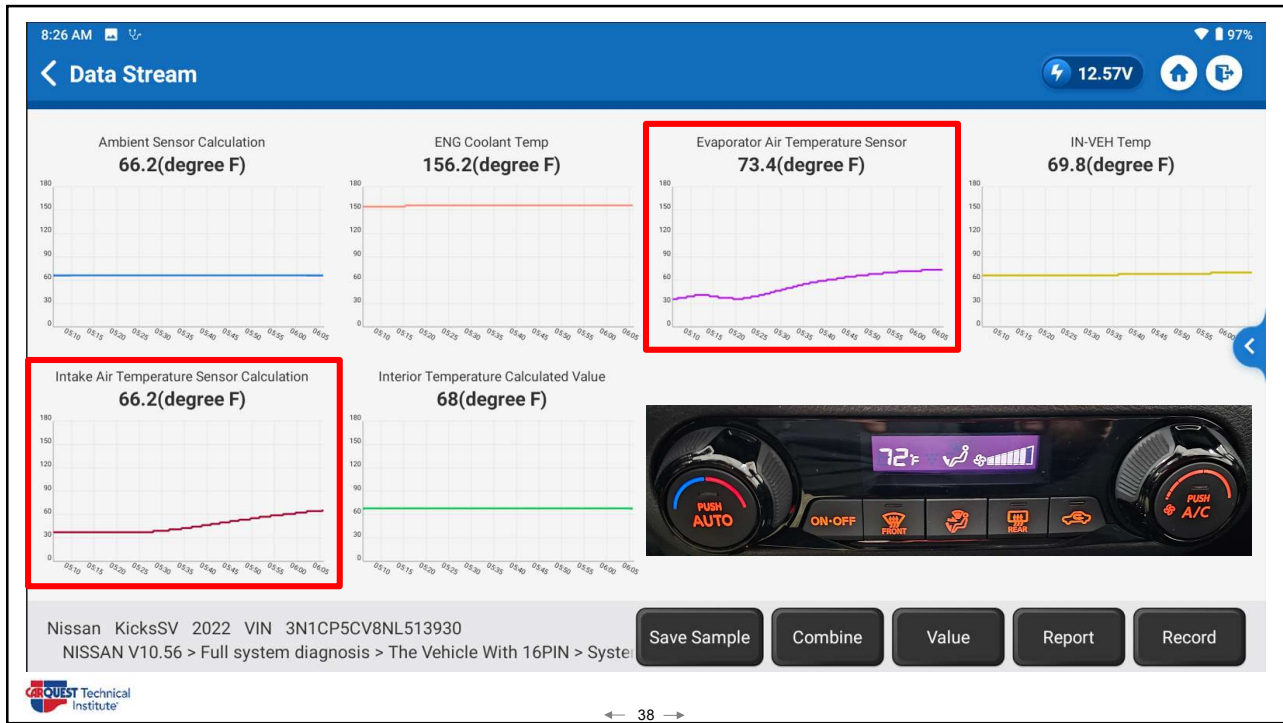

## 2022 Nissan Kicks – Service Information Video

MOTOLOGIC

REPAIR & DIAGNOSTICS

---

2022 Nissan Kicks ← Back to Car
Print | Bookmark | Article Info

- ▶ Operation
- ▶ System
  - Air Flow Control
  - Air Inlet Control
  - Air Outlet Control
  - Compressor Control
  - Door Control
  - System Description
  - Temperature Control
- ▶ Wiring Diagram
- ▶ Manual Air Conditioning
- ▶ Heater & Air Conditioning System
- ▶ Ventilation System
- ▶ Labor Times
- ▶ MotoLogic Color Wiring
- ▶ Service Bulletins

### Ventilation, Heater & Air Conditioner > Heater & Air Conditioning Control System > Automatic Air Conditioning > System Description > System > System Description

System Description

#### SYSTEM DIAGRAM

← 40 →

## A/C Auto Amp – Consult (Scan Tool) Function

MOTOLOGIC

REPAIR & DIAGNOSTICS

---

2022 Nissan Kicks ← Back to Car
Print | Bookmark | Article Info

- ▶ Diagnosis System (A/C Auto AMP.)
  - Consult Function (HVAC)
  - Description
- ▶ Diagnosis System (BCM)
- ▶ Air Conditioner
  - Consult Function (BCM - Air Conditioner)
- ▶ Diagnosis System (IPDM E/R)
  - Consult Function (IPDM E/R)
- ▶ Operation
- ▶ System
- ▶ Wiring Diagram
- ▶ Manual Air Conditioning
- ▶ Heater & Air Conditioning System

### Automatic Air Conditioning > System Description > Diagnosis System (A/C Auto AMP.) > Consult Function (HVAC)

CONSULT Function (HVAC)

CONSULT can display each diagnosis item using the diagnosis test modes as shown.

Diagnosis Mode	Description
Self Diagnostic Result	Displays the diagnosis results judged by A/C auto amp.
Data Monitor	Displays A/C auto amp. input/output data in real time.
Work support	Changes the setting for each system function.
Active Test	The signals used to activate each device are forcibly supplied from A/C auto amp.
ECU Identification	Displays the A/C auto amp. number.

← 41 →

### TOPDON Scan Tool

2:54 PM 14.66V 88%

< Show Menu

- Module Information
- Read Fault Code
- Clear Fault Code
- Read Data Stream
- Actuation Test
- Work Support

Nissan KicksSV 2022 VIN 3N1CP5CV8NL513930  
 > Automatically Search > North America > North America Common > KICKS > P15 > /2022 -> Heating, Ventilation & Air Conditioning syste

← 42 →

### Scan – System Topology

2:54 PM 14.73V 88%

< System and Function

System Topology System List multiple system data stream On

\*Support sliding up and down

OBD

Body: SRS, IC, HVAC

Other: BCM, HLL, 3GW

Power: ODS, ECM, IPDM, TCM

Heating, Ventilation & Air Conditioning system(HVAC)

DTC(s): 1

**B24A9-15** Sunload Sensor

CRNT

Enter

NIS Report Diagnostic Plan Clear DTCs

Nissan KicksSV 2022 VIN 3N1CP5CV8NL513930  
 > North America Common > KICKS > P15 > /2022 - >

← 43 →

### DTC - B249-15

**B249-15**  
Sunload Sensor

CRNT

Freeze Frame Code Search

NISSAN KICKS SV 2022 VIN 3N1CP5CV8NL513930

N V10.52 > Full system diagnosis > The Vehicle With 16PIN > System Selection > Ventilation, Heater & Air Conditioner > HVAC (Heating)

Report

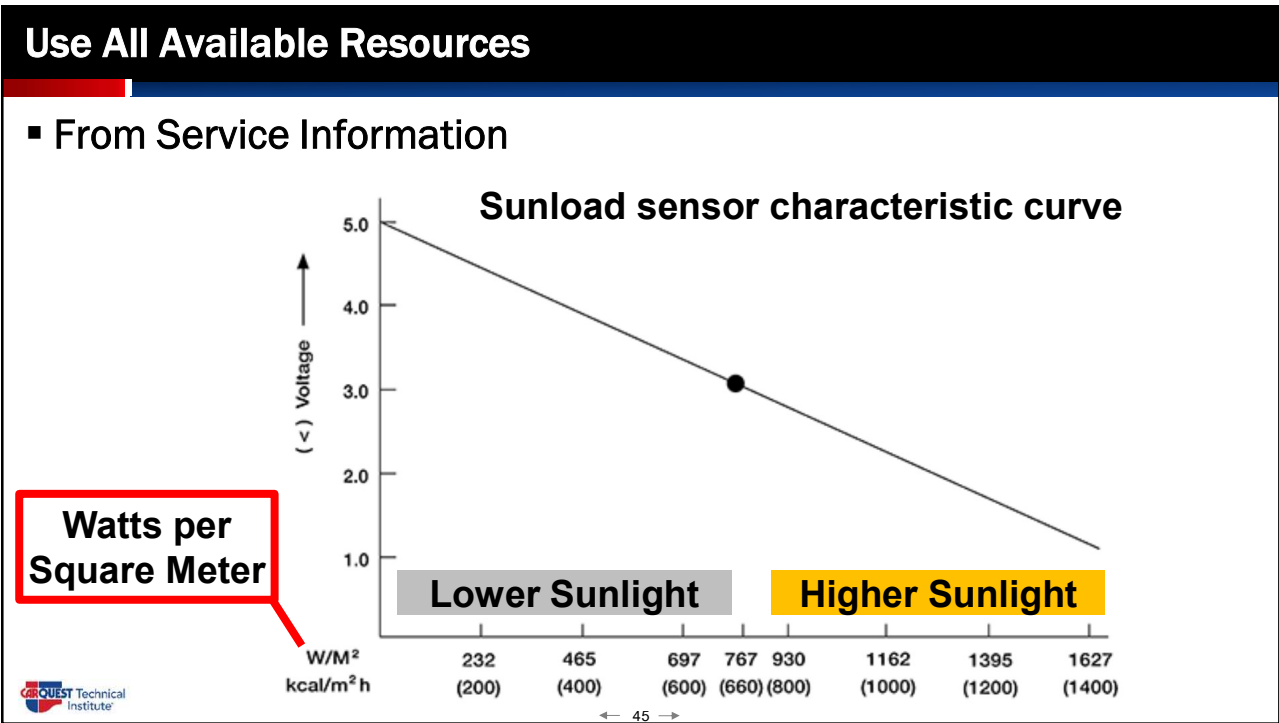

# What's in a Name?

- Sunshine Sensor
  - Nissan Example (In-Shop)

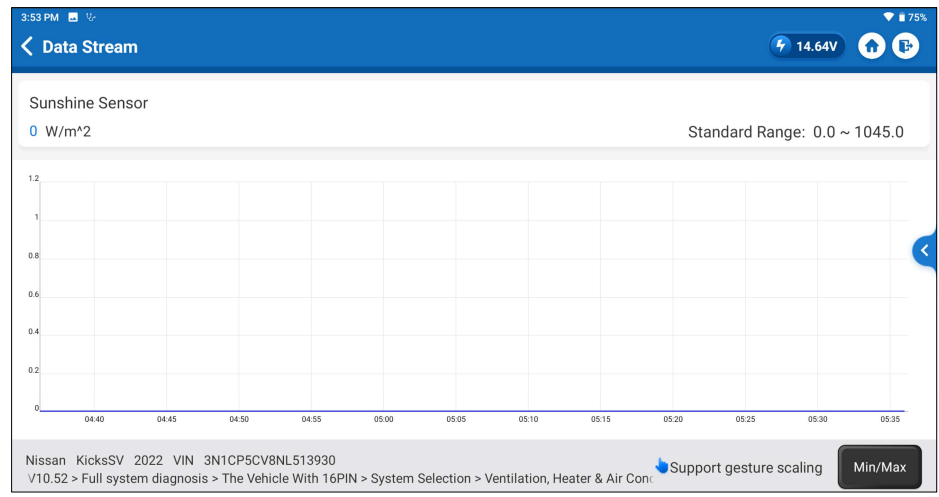

# What does W/m^2 Mean?

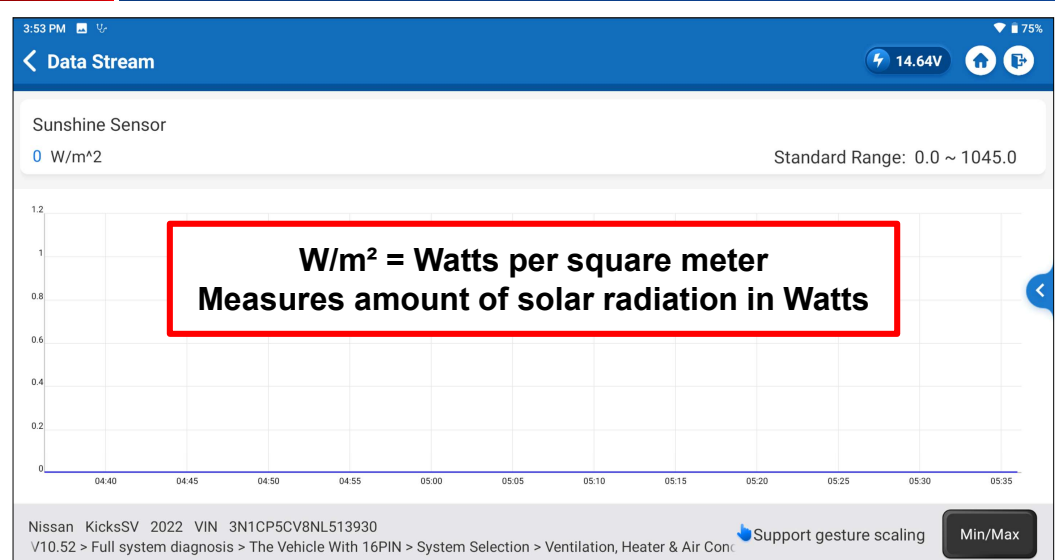

## Component Inspection - Sunload Sensor

- Ignition Switch ON
- Check voltage
  - Between A/C auto amp harness connector and ground.

(+)		(-)
A/C auto amp.		
Connector	Terminal	
M50	47	Ground

**Note:**



Select a place in direct sunlight when checking sunload sensor.



## DTC Detection Logic

- B24A9-15 Sunload Sensor – (Circuit Shorted to Battery or Open)
  - Detected calorie at sunload sensor is 33 w/m<sup>2</sup> (28 kcal/m<sup>2</sup>.h)
- Three Possible Causes
  - Sunload Sensor
  - A/C auto amplifier
  - Harness or connectors

**Note:**



If DTC is displayed along with DTC U1000-01 or U1010-49, first diagnose the DTC U1000-01 or U1010-49. Refer to [DTC Description \(U1000-01\)](#) or [DTC Description \(U1010-49\)](#).

Sunload sensor may register a malfunction when indoors, at dusk, or at other times when light is insufficient. When performing the diagnosis indoors, light the sunload sensor with a lamp (60W or more).



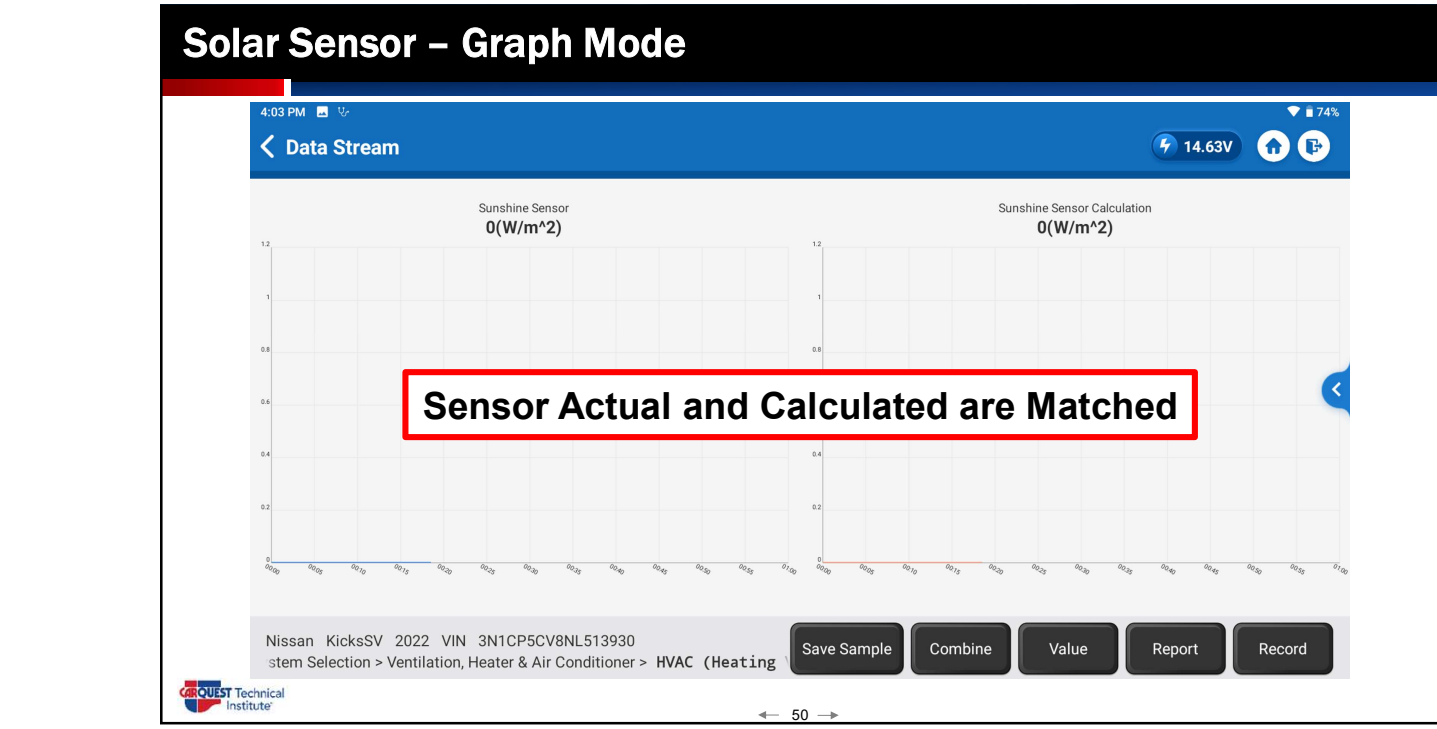

## Diagnostic Procedure – STEP 1

- Sunload Sensor Power Supply
  - Ignition OFF – Disconnect sensor
  - Ignition ON
    - Check voltage between sensor harness connector and ground

(+)		(-)	Voltage (Approx.)
Connector	Terminal		
M107	1	Ground	5 V



**Results Normal?  
YES - GO TO 2**



**Results Normal?  
NO - GO TO 4**



← 52 →

## Schematic 2

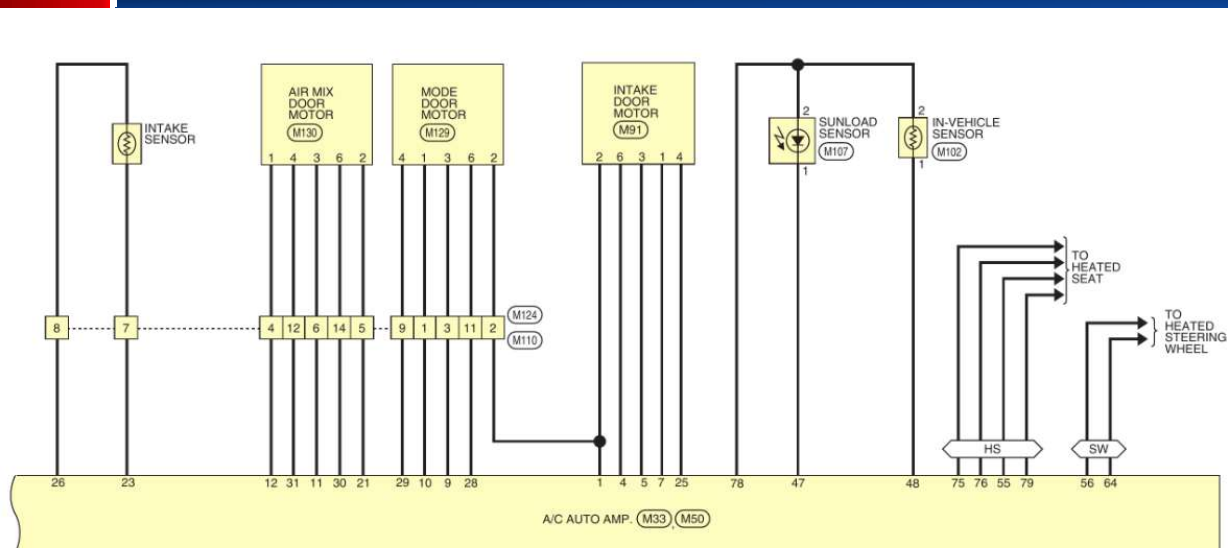

← 53 →

## Diagnostic Procedure – STEP 2

- Check Continuity between Sunload Sensor and A/C Auto Amplifier
  - Ignition switch OFF
    - Disconnect A/C Auto Amplifier connector
      - Check continuity between sensor and A/C Auto Amplifier harness connectors

Sunload sensor		A/C auto amp.		Continuity
Connector	Terminal	Connector	Terminal	
M107	2	M50	78	Yes



**Results Normal?  
YES - GO TO 3**



**Results Normal?  
Repair harness or  
Connector**



## Diagnostic Procedure – STEP 3

- Check Sunload Sensor
  - Reconnect Sunload Sensor and A/C Auto Amplifier connector
  - Inspect Sensor according to **Component Inspection**
    - Result normal? YES - Replace A/C Auto Amplifier
    - NO – Replace Sunload Sensor



## Diagnostic Procedure – STEP 4

- Check continuity between Sunload Sensor and A/C Auto Amplifier
  - Ignition OFF
    - Disconnect A/C Auto Amplifier connector
      - Check continuity between sensor harness connector and A/C auto amplifier connector

Sunload sensor		A/C auto amp.		Continuity
Connector	Terminal	Connector	Terminal	
M107	1	M50	47	Yes

**Results Normal?  
YES - GO TO 5**

- Check continuity between Sunload Sensor harness connector and ground

Sunload sensor		—	Continuity
Connector	Terminal		
M107	1	Ground	No

**Results Normal?  
NO  
Repair harness or  
Connector**



← 56 →

## Diagnostic Procedure – STEP 5

- Check Sunload Sensor Power Supply circuit for Power Short
  - Ignition Switch ON
  - Check voltage between sunload sensor harness connector and ground

(+)		(-)	Voltage (Approx.)
Sunload sensor			
Connector	Terminal		
M107	1	Ground	0 V

**Results Normal?  
YES –  
Replace A/C  
auto amplifier**

**Results Normal?  
NO  
Repair harness or  
Connector**



← 57 →

# Wiring Schematic 1

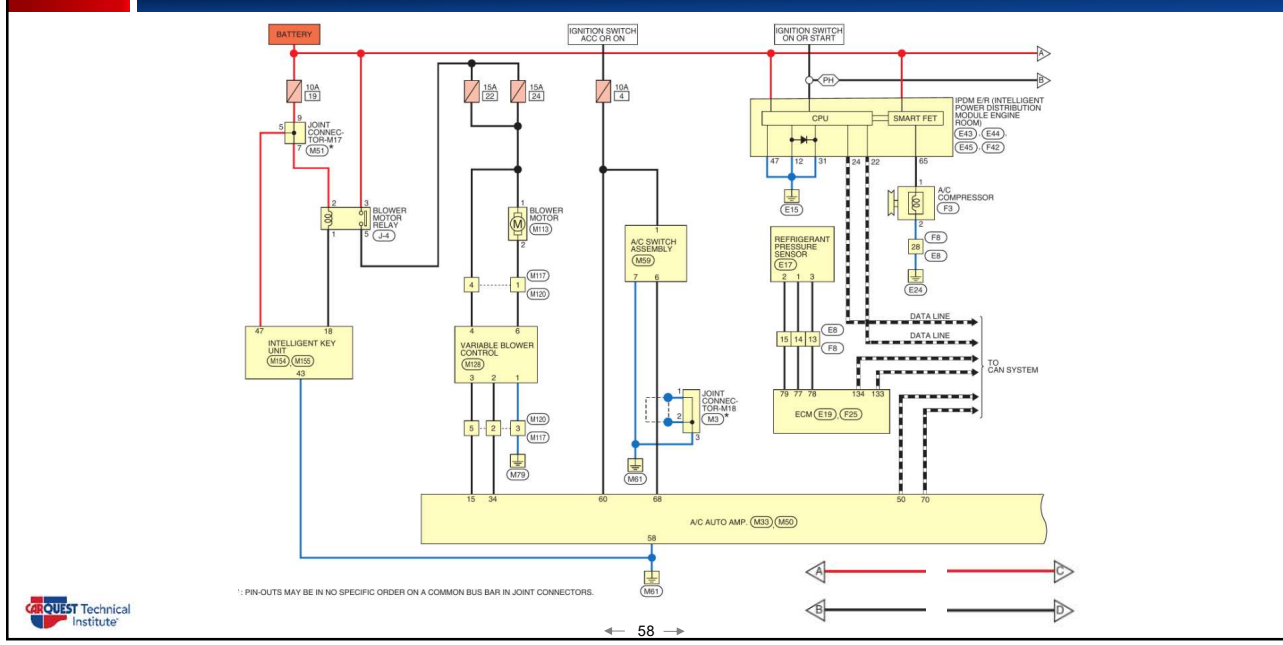

# Schematic 2

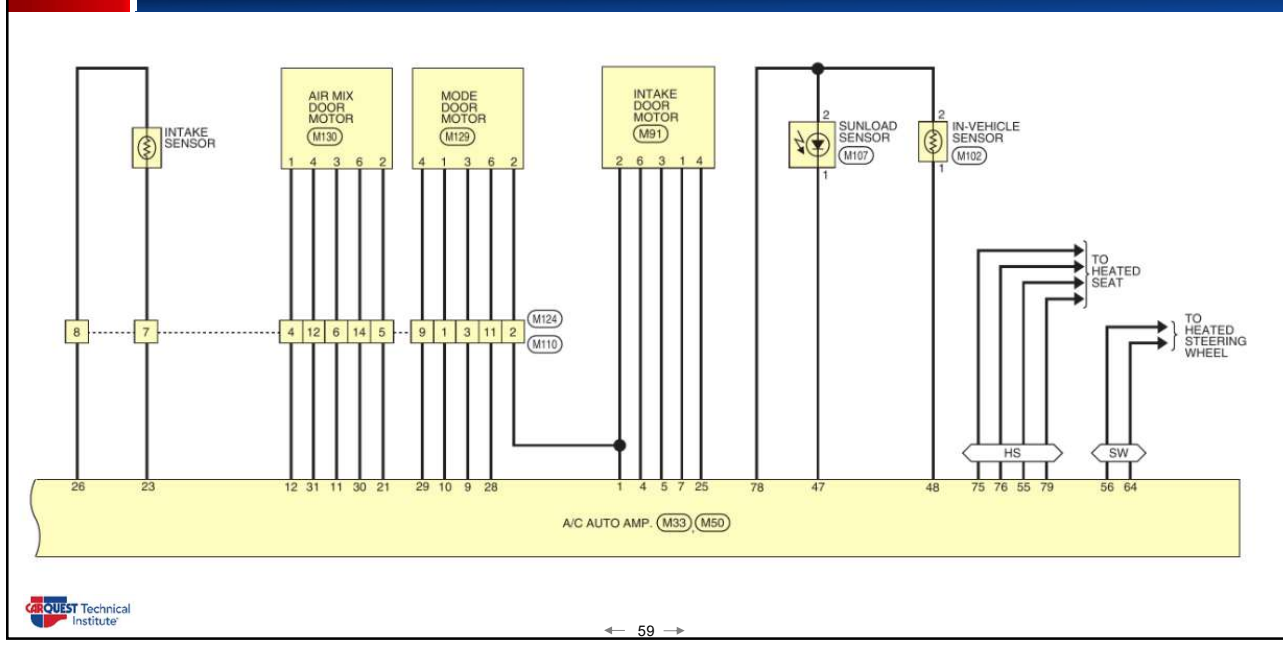

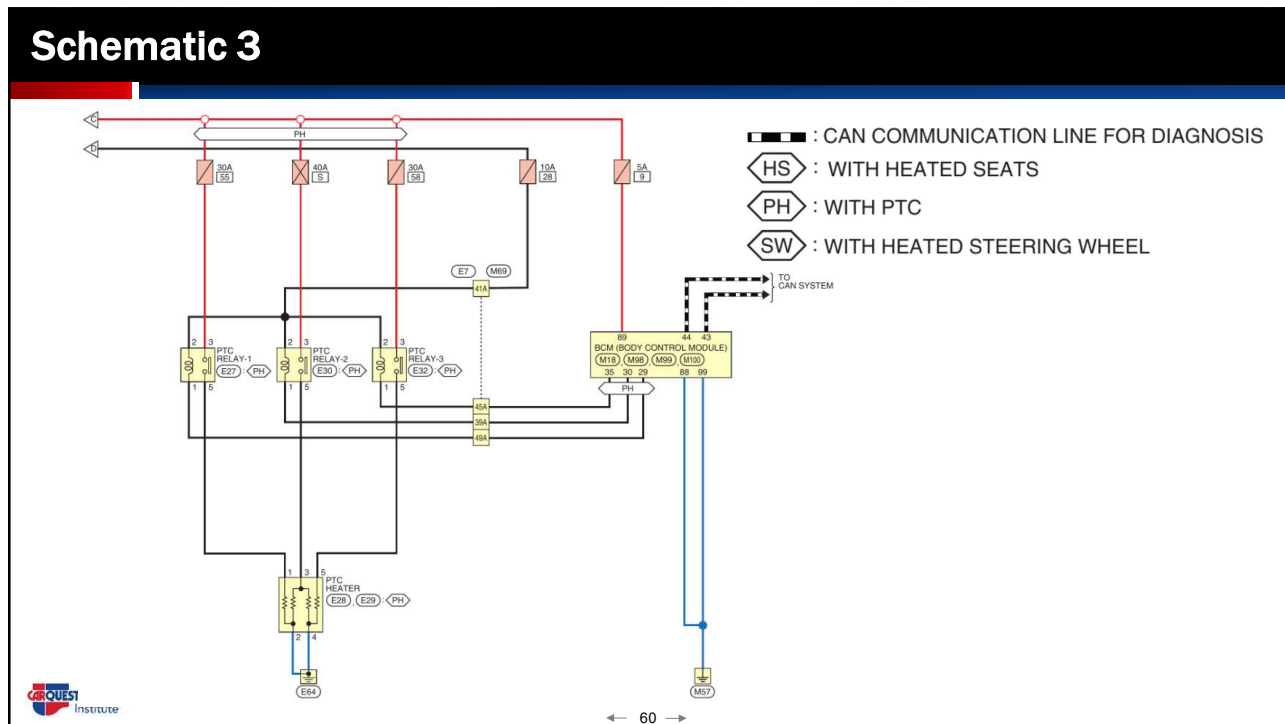

### Diagnosis By Symptom

- Listen to the customer carefully!
  - Diagnosis DOES NOT have to be DIFFICULT

▼ Symptom Diagnosis

- ▶ Compressor Does Not Operate
- ▶ Heater and Air Conditioning System Control Symptoms

**Check  
DTCs  
FIRST!**

▶ Insufficient Cooling

▶ Insufficient Heating

**Diagnosis Chart By Symptom**

GUID-4BF87ED-7AD9-44DC-BE5A-A61705F07E8F

**Note:**

Perform the self-diagnosis with CONSULT before performing the symptom diagnosis. If DTC is detected, perform the corresponding diagnosis.

## Diagnosis by Symptom - Example

**Note:**



Perform the self-diagnosis with CONSULT before performing the symptom diagnosis. If DTC is detected, perform the corresponding diagnosis.

Symptom	Corresponding malfunction part	Reference
A/C compressor does not operate.	<ul style="list-style-type: none"> <li>Circuit between magnet clutch and IPDM E/R</li> <li>Magnet clutch</li> <li>IPDM E/R</li> <li>Circuit between ECM and refrigerant pressure sensor</li> <li>Refrigerant pressure sensor</li> <li>CAN communication circuit</li> <li>A/C auto amp.</li> </ul>	Refer to <a href="#">Diagnosis Procedure</a> .



## Automatic A/C Initialization

3:10 PM 14.72V 85%

< Show Menu

- Temperature Setting Correct
- Blowing-In Setting
- Evaporator Target Temperature Upper Limit Setting**
- Intake Air Conversion Setting
- Air Flow Decrease Setting
- Stop/Start System Operation Cond Setting

Nissan KicksSV 2022 VIN 3N1CP5CV8NL513930  
 NISSAN V10.52 > Common Special Function >Automatic air conditioning initialization >



### Information Screen

3:11 PM 14.68V 84%

Information

Corrects The Controlled Temperature Of Auto Amp. For The Preset Temperature When The Actual Discharged Air Temperature And Passenger's Sensible Temperature Are Different.

Cancel OK

Nissan KicksSV 2022 VIN 3N1CP5CV8NL513930  
NISSAN V10.52 > Common Special Function > Automatic air conditioning initialization >

← 64 →

### Execute Function

3:12 PM 14.69V 84%

Brush Hidden/Modified

Item	Value	Help Information
Evaporator Target Temperature Upper Limit Setting	Initial Setting	

Nissan KicksSV 2022 VIN 3N1CP5CV8NL513930  
> Common Special Function > Automatic air conditioning initialization > Evaporator Target Temperature Upper Limit Setting EXEC

← 65 →

## Success

← 66 →

## Temperature Setting Trimmer

Work support items	Display (°F)	Display (°C)
TEMP SET CORRECT	6	3.0
	5	2.5
	4	2.0

**Note:**

When the temperature setting is set to 25.0°C (77°F) and -3.0°C (-6°F), the temperature controlled by auto amp is 25.0°C (77°F) - 3.0°C (6°F) = 22.0°C (71°F) and the temperature becomes lower than the temperature setting.

When the battery cable is disconnected from the negative terminal or when the battery voltage becomes 10V or less, the setting of the difference between the temperature setting and control temperature may be cancelled.

	-6	-3.0
--	----	------

← 67 →

# Sensor Calibration Errors

- Check them against themselves

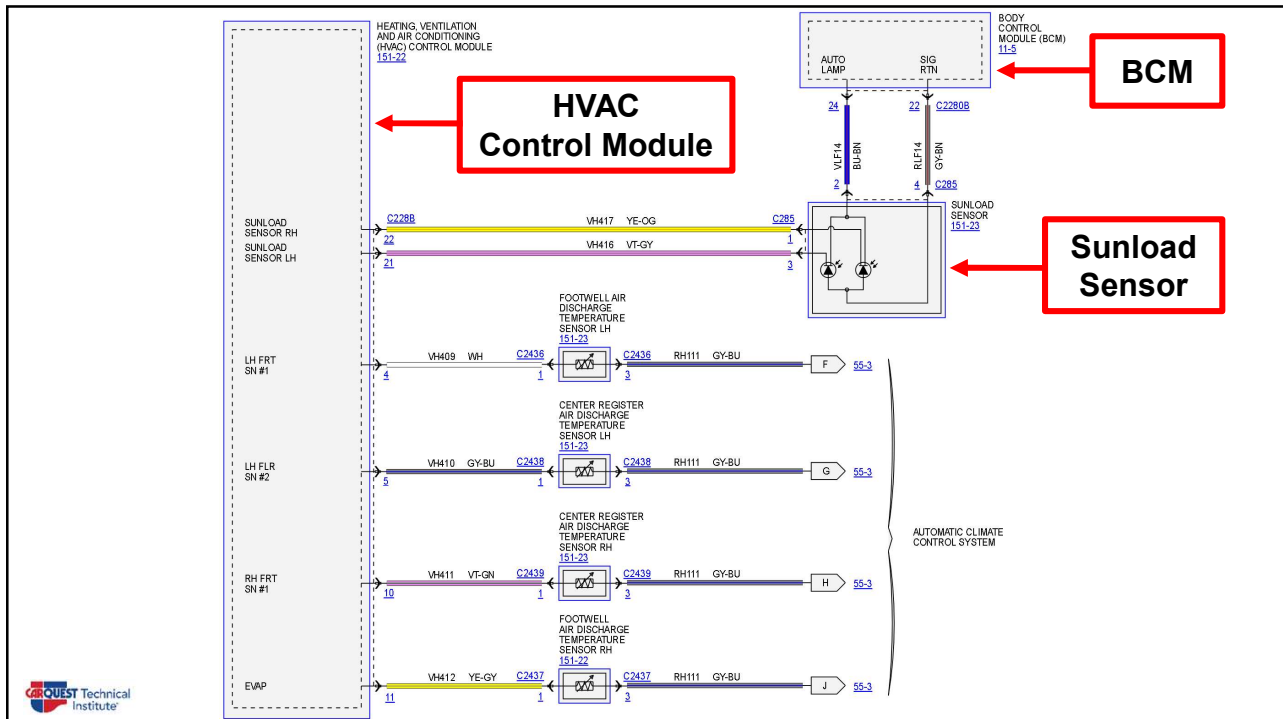

## Carbon Dioxide (CO<sub>2</sub>) Sensor

- **Sense occupant respiration**
  - Increased CO<sub>2</sub> levels cause drowsiness
  - Should be less than 1,000ppm
    - 4 adult's commute - 6k ppm
- **Lack of adequate ventilation**
  - Accounts for 10-30% of all automobile accidents annually
- **Automatic Climate Control**
  - Opens fresh air door
    - Mitigates risk of high CO<sub>2</sub> exposure

### CO<sub>2</sub> Sensor



Hyundai Genesis

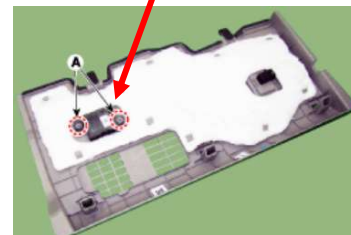

## SAE Article

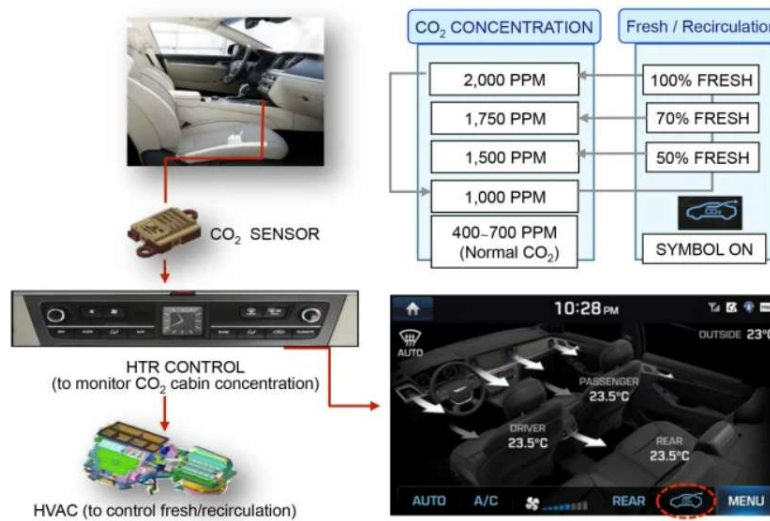

# Hyundai Genesis

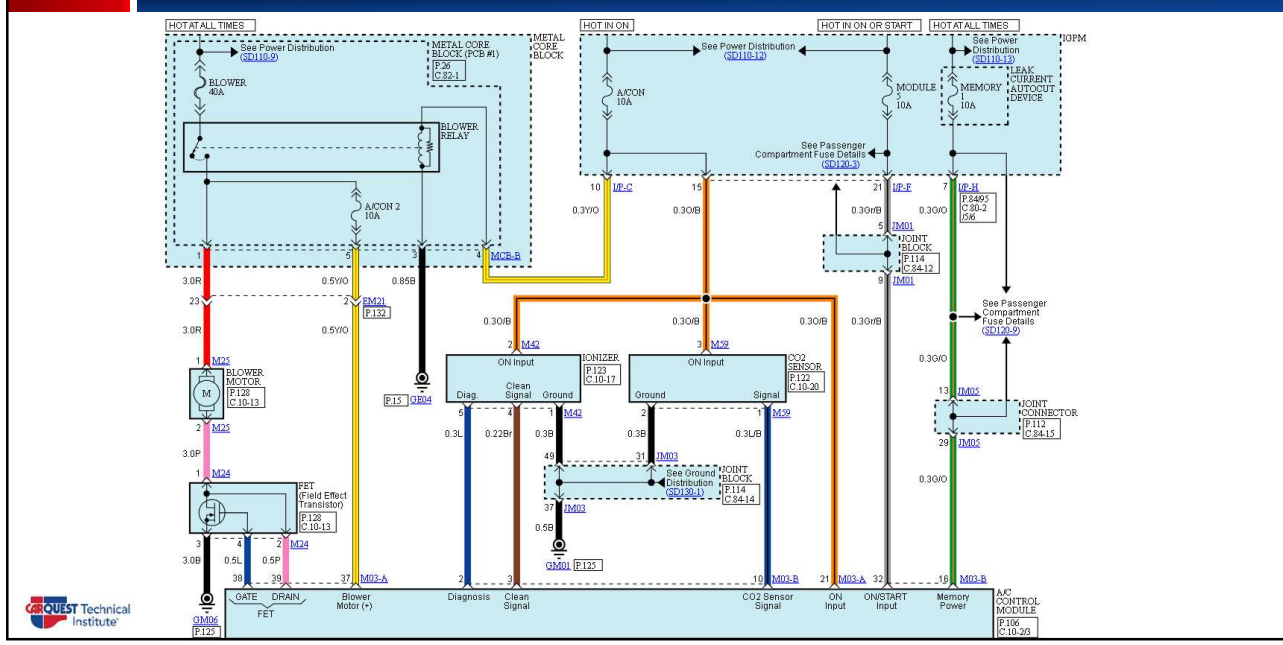

# Cluster Ionizer

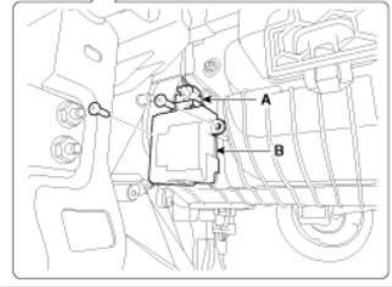
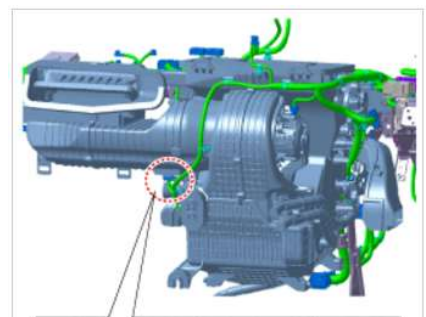

## Humidity Sensors

- Inside Vehicle
  - Relative humidity at windshield
  - Temperature of windshield
  - Temperature of humidity sensor element
- Contained in one assembly
  - Hard wired to HVAC Module

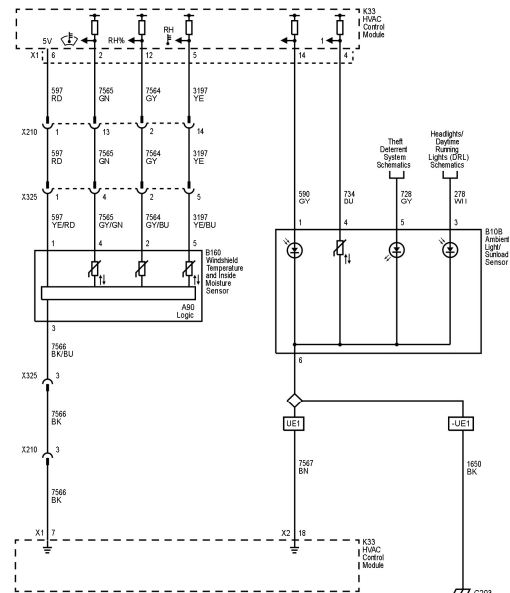

← 74 →

## Rain Sensors

- Rain Sensor
  - Senses rain build up on windshield
- Communicates with BCM
  - Via serial data
  - BCM commands wipers to activate
- Wiper/washer switch
  - Controls Wipe sensitivity frequency set by delay function
  - Vehicle speed increases frequency



← 75 →

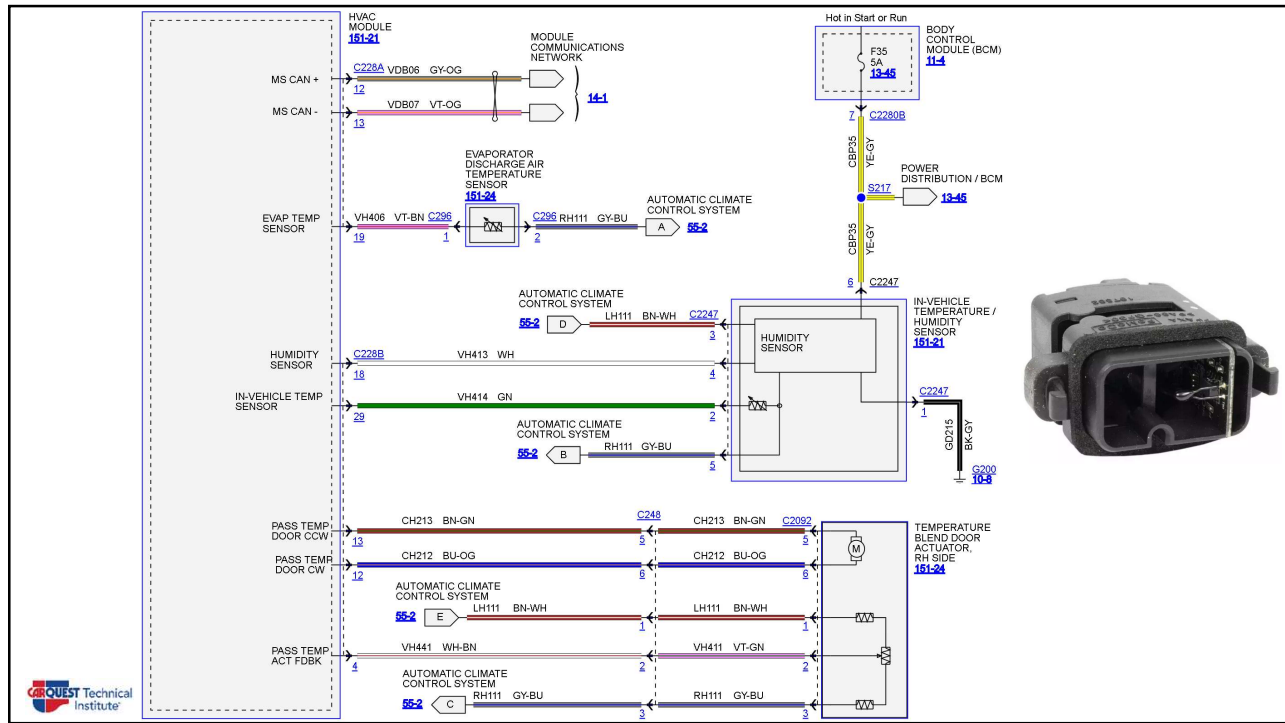

## Ford Rain Sensor - Example

- BCM Powered off Run/ACC Relay - Non serviceable

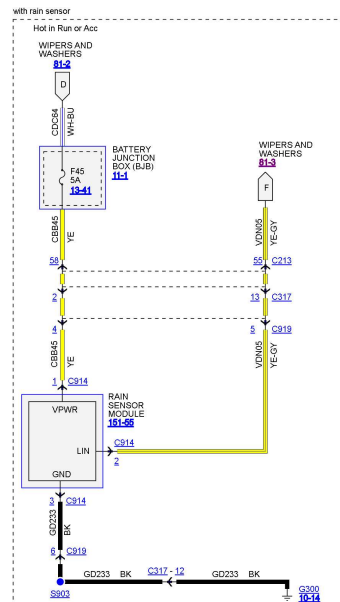
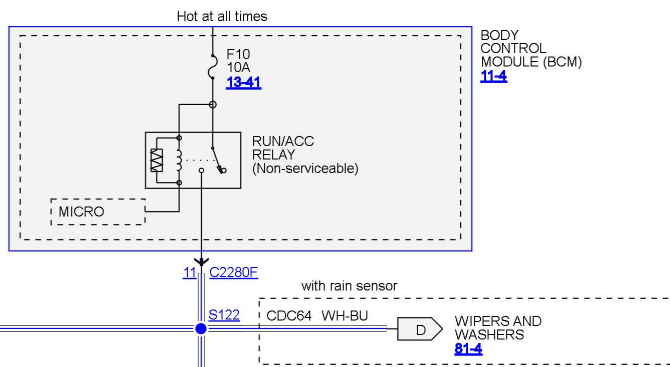

# LIN Bus Analytics

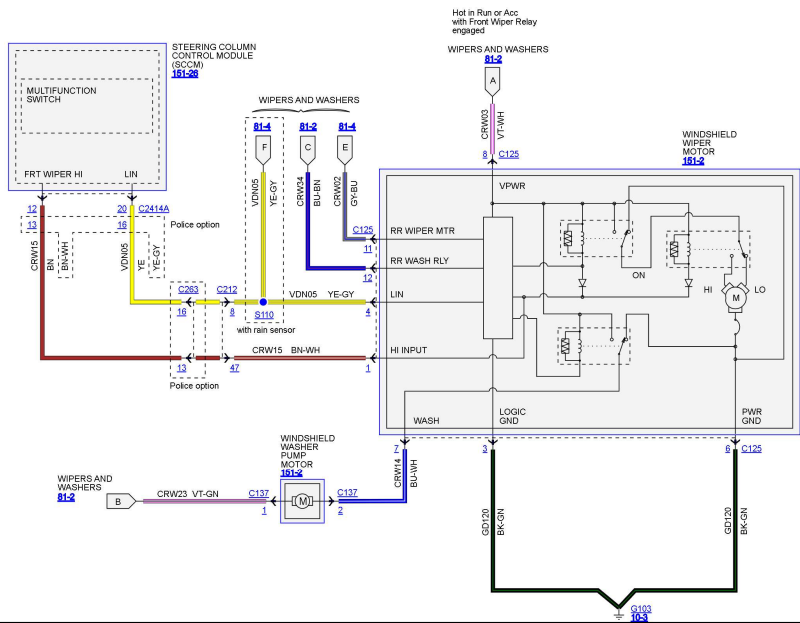
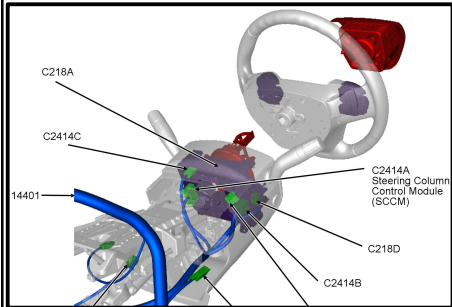

# Checking Rain Sensor



### 2019 Chevy Bolt EV



**Uses Three Independent Cooling Systems**

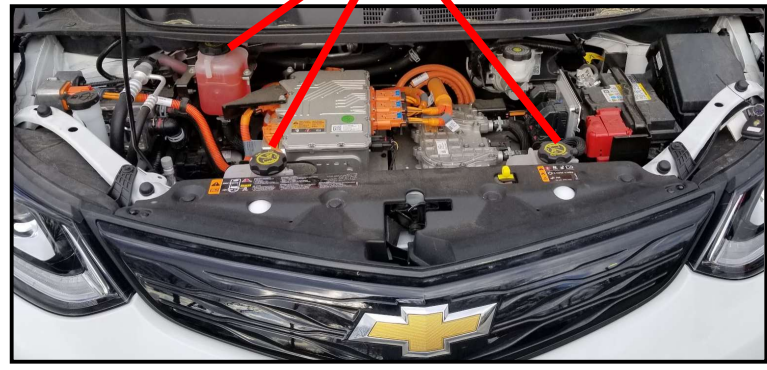

### Hybrid & EV Cooling Systems

- Cooling System Loops
- More than one reservoir
  - Energy Storage (HV Battery)
  - Power Electronics
  - Heater Core

**2019 Chevy Bolt EV**

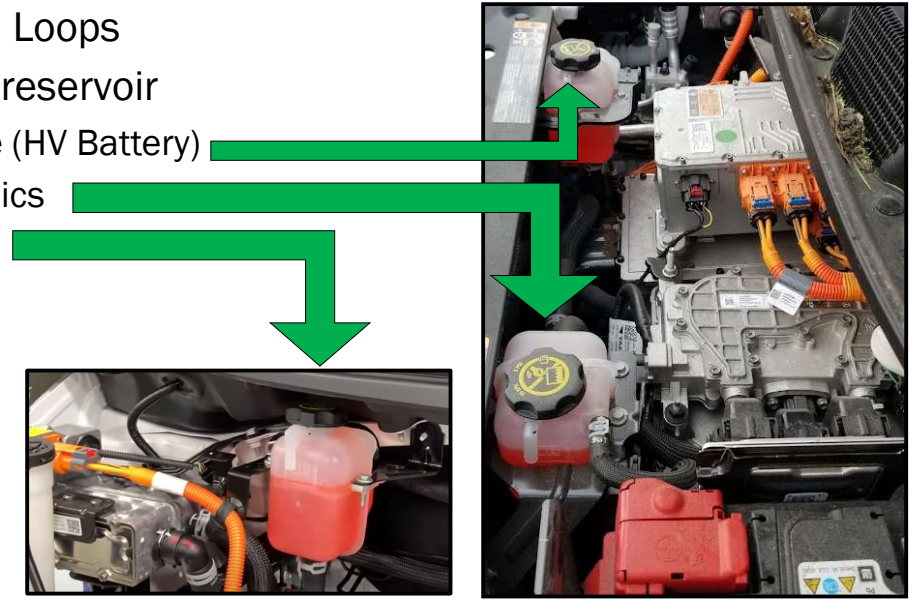

# E/V Battery Temperature Sensors

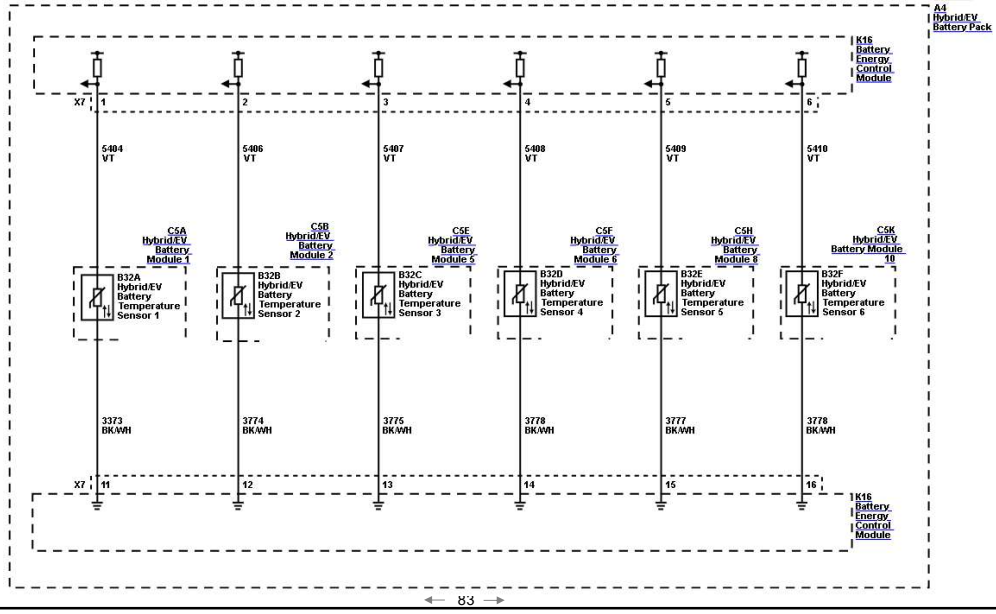

← 83 →

# Scan Tool View

**Chevrolet**  
V2.40-10.10

Chevrolet > Automatic selection > Control unit > Battery energy control module > Live data

Name	Value	Range	Unit
<input type="checkbox"/> Hybrid/ev battery 1	71.6	[-40.00...419.00]	°F
<input type="checkbox"/> Hybrid/ev battery 2	71.6	[-40.00...419.00]	°F
<input type="checkbox"/> Hybrid/ev battery 3	71.6	[-40.00...419.00]	°F
<input type="checkbox"/> Hybrid/ev battery 4	73.4	[-40.00...419.00]	°F
<input type="checkbox"/> Hybrid/ev battery 5	71.6	[-40.00...419.00]	°F
<input type="checkbox"/> Hybrid/ev battery 6	71.6	[-40.00...419.00]	°F
<input type="checkbox"/> Hybrid/ev batt. pack clnt. temp. sensor 1	69.8	[-40.00...419.00]	°F



← 84 →

## E/V Battery Pack Coolant Heater

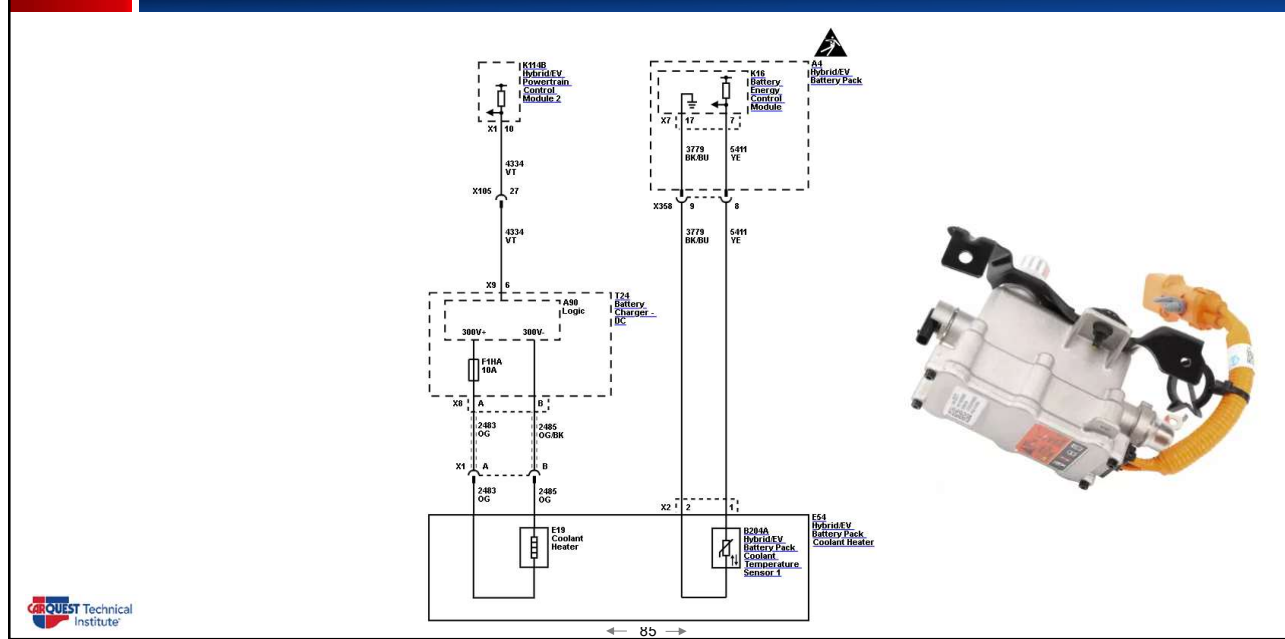

## Battery Pack Coolant Pump

Chevrolet V2.40-10.10

Chevrolet > Automatic selection > Control unit > Hybrid/ev powertrain control module 2 > Active test

Hybrid/ev battery pack coolant pump(Temperature)

Hybrid/ev battery pack coolant pump command	50	%
Average hybrid/ev battery pack temperature	71.60	°F
Hybrid/ev batt. pack clnt. temp. sensor 1	78.80	°F
Hybrid/ev battery pack coolant pump feedback	50	%
Hybrid/ev electronics coolant temperature	75.20	°F
Hybrid/ev electronics coolant pump command	6	%
Hybrid/ev electronics coolant pump feedback	0	%
Hybrid/ev electronics coolant pump speed	50	RPM
Hybrid/ev battery pack heater power command	0	%

VIN: 1G1FW6S07P4119071  
Info: Chevrolet/Bolt

Increase Decrease ESC

# E/V Electronics Cooling

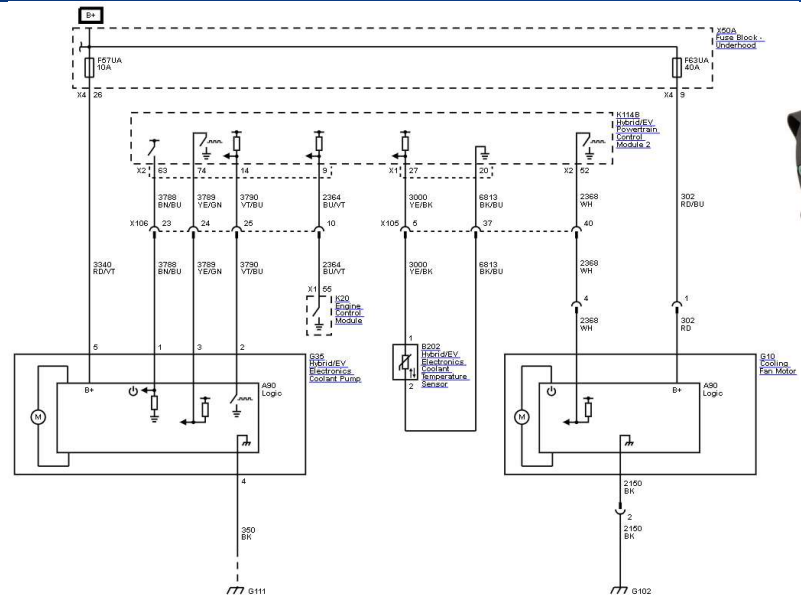

# Coolant Pump Active Test

Chevrolet V2.40-10.10

Chevrolet > Automatic selection > Control unit > Hybrid/ev powertrain control module 2 > Active test

Hybrid/ev electronics coolant pump(Temperature)

Hybrid/ev electronics coolant pump command	30	%
Hybrid/ev electronics coolant pump command	30	%
Hybrid/ev electronics coolant pump feedback	50	%
Hybrid/ev electronics coolant pump speed	1350	RPM
Ambient air temperature	71.60	°F
Maximum hybrid/ev battery module temperature	73.40	°F
Minimum hybrid/ev battery module temperature	71.60	°F
Hybrid/ev batt. temp. sensor with max. value	4	
Hybrid/ev batt. temp. sen. with min. value	1	

WIN: 161FW6S07P4119071  
Info: Chevrolet/Bolt

Increase Decrease ESC



# Cooling Fan Motor Active Test

Chevrolet V2.40-10.10

Chevrolet > Automatic selection > Control unit > Hybrid/ev powertrain control module 2 > Active test

VCMS 12.4V

Cooling fan motor(Temperature)		
Cooling fan motor command	20	%
Cooling fan motor command	20	%
Ambient air temperature	71.60	°F
Maximum hybrid/ev battery module temperature	73.40	°F
Minimum hybrid/ev battery module temperature	71.60	°F
Hybrid/ev batt. temp. sensor with max. value	4	
Hybrid/ev batt. temp. sen. with min. value	1	
Average hybrid/ev battery pack temperature	71.60	°F
Hybrid/ev batt. pack clnt. temp. sensor 1	84.20	°F

VIN: 1G1FW6S07P4119071  
Info: Chevrolet/Bolt

Increase Decrease ESC



← 89 →

# In-Car Temperature Sensors

## ■ Chevy Bolt E/V

## ■ Wiring Function

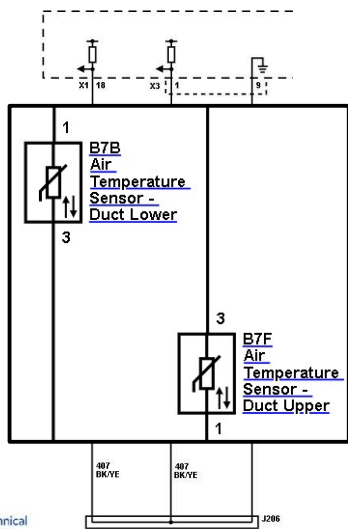

Pin	Size	Color	Circuit	Function
1	—	BK/YE	407	Sensor Low Reference
2	—	—	—	Not Occupied
3	—	GY/GN	516	Upper Left Air Temperature Sensor Signal



← 90 →

# Application of PTC Thermistors

- **Self Regulating Heaters**
  - Maintain steady temperatures
    - By increasing resistance
- **Temperature Sensing**
  - Predictable resistance rise
    - Ideal for temperature monitoring
- **Overcurrent Protection**
  - Increases resistance
    - Circuit protection
    - Acts as resettable fuses

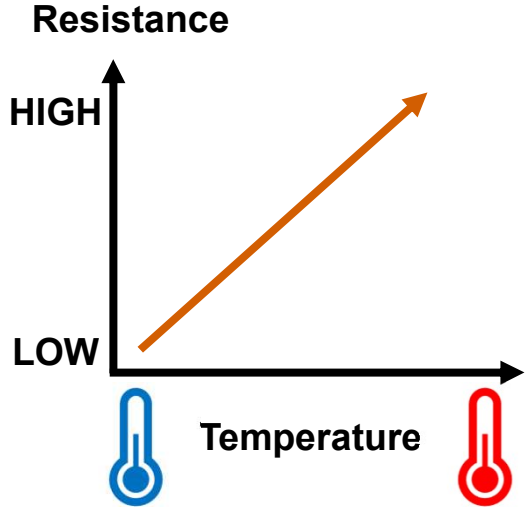

# P.T.C. Heater – BMW Example

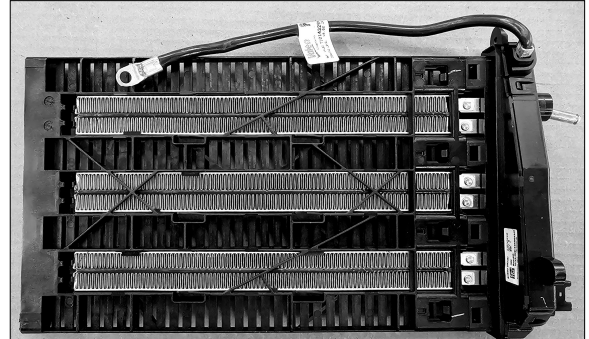
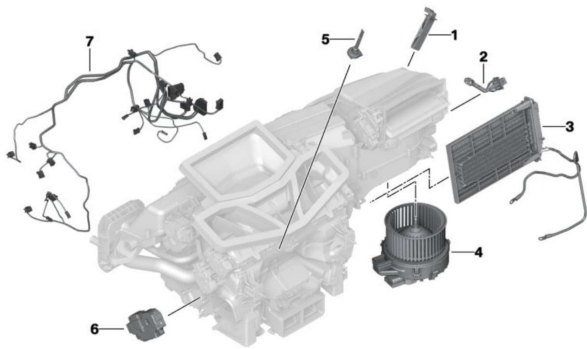

## P.T.C. Heater - 2021 Jeep G.C. Example

- 3.0L Diesel Engine
  - Mounted in HVAC housing
  - Controlled by PCM and BCM
- Split into 3 banks
  - Driven separately
    - By alternator load
    - Allows for lower in-rush current
- Banks are alternated
  - 10 seconds after previous one
  - Wattage output between 900-1050 W.
- Always check for DTCs FIRST!
  - All Module Scan
    - BCM, PCM and HVAC
  - BCM receives CAN bus Message from PCM
  - BCM controls ALL PTC relays
    - B10B3-14 Cabin Heater 1
    - B10B7-14 Cabin Heater 2
    - B1137-14 Cabin Heater 3



## BCM – Diagnosis & Testing



2021 Jeep Grand Cherokee ← Back to Car

Print Bookmark Article

▼ Module, Body Control (BCM)

▼ Diagnosis and Testing

- B10B3-14-Cabin Heater 1 Control-Circuit Short to Ground or Open
- B10B7-14-Cabin Heater 2 Control-Circuit Short to Ground or Open
- B1137-14-Cabin Heater 3 Control-Circuit Short to Ground or Open
- B1208-11-Anti-Theft Indicator-Circuit Short to Ground
- B1208-15-Anti-Theft Indicator-Circuit Short to Battery or Open
- B1609-11-Panel Dimmer Input-Circuit Short to Ground
- B1609-15-Panel Dimmer Input-Circuit Short to Battery or Open

Service Information > 28 - DTC-Based Diagnostics > Module, Body Control (BCM) > Diagnosis and Testing > B10B3-14-Cabin Heater 1 Control-Circuit Short to Ground or Open

[Report a problem with this article](#)

**B10B3-14-CABIN HEATER 1 CONTROL-CIRCUIT SHORT TO GROUND OR OPEN**

For a complete CABIN HEATER SYSTEM wiring diagram, (refer to the [Wiring Information](#)) .

Theory of Operation - Relays

In diesel applications there are three Positive Temperature Coefficient (PTC) Relays, located in the Power Distribution Center (PDC) Assembly, are used for the PTC Cabin Heater System. The PTC Relays are used to supply fused battery voltage directly to the heating elements of the Cabin Heater. When the Body Control Module (BCM) receives a PTC Cabin Heater System activation CAN Bus message from the Powertrain Control Module (PCM), the BCM provides a ground signal, through the PTC Relay Control circuits, to activate the PTC Relays. When the PTC Relays are activated, a voltage output is sent to the Cabin Heater through the Fused Cabin Heater Supply circuits.





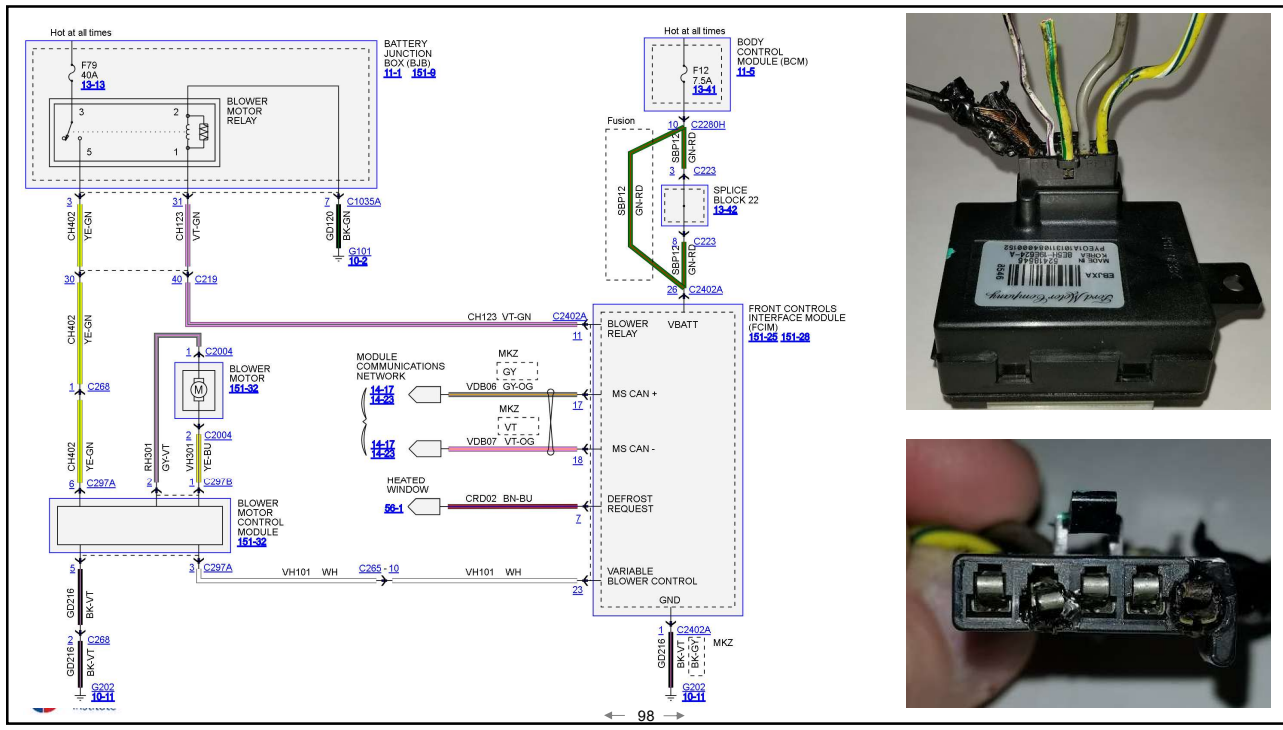
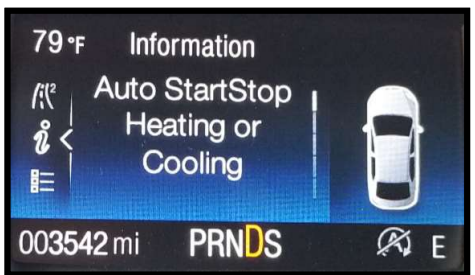
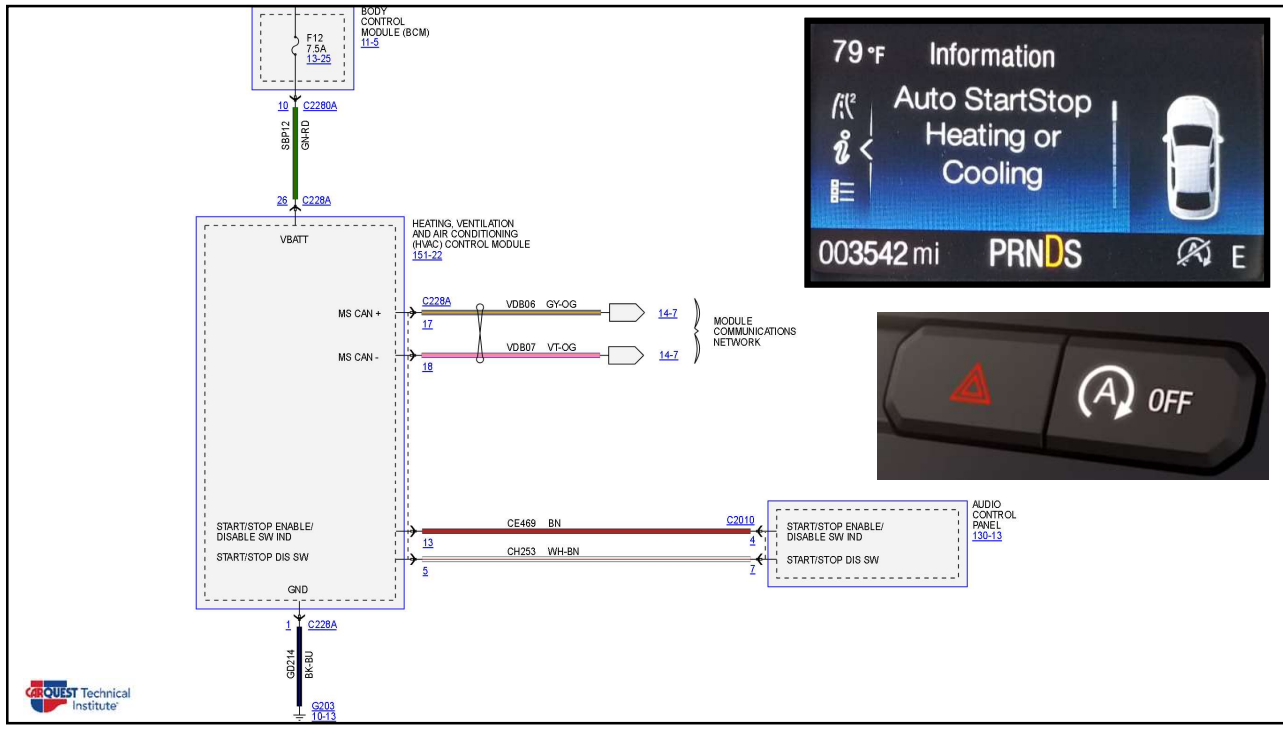

# Blower Motor Current Test – Stepped Resistors



Low Amp Clamp Connection



Low Speed



Medium 2



Medium Speed 3

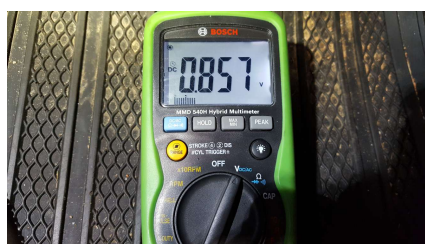

High Speed



# Audi Cooling Fan Analytics

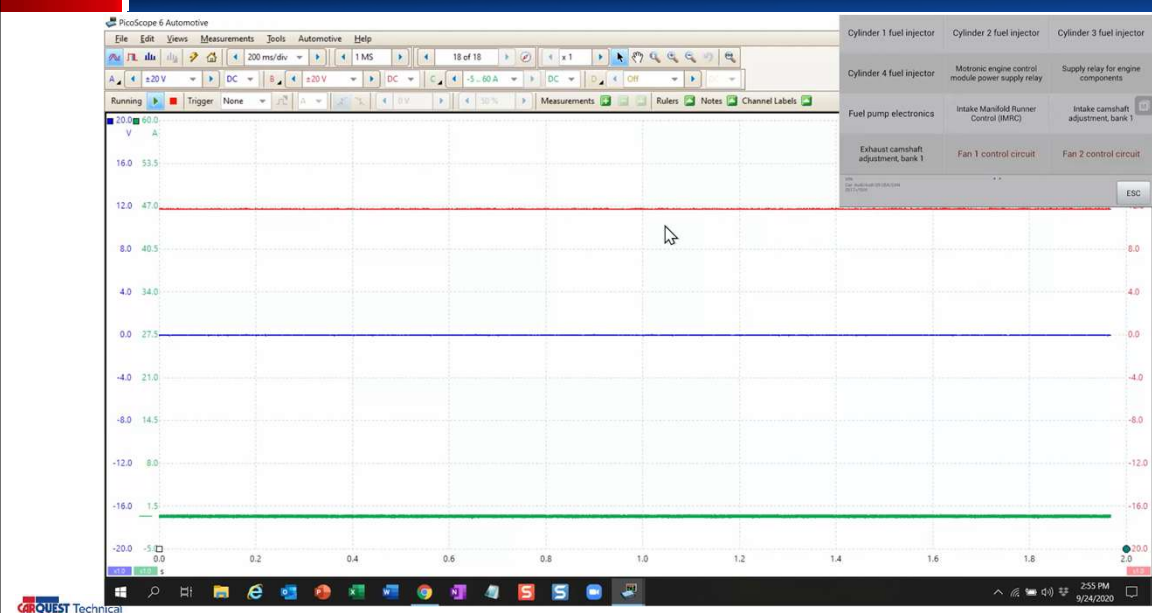

## HVAC Door Actuators

- High Failure rate item
  - Noise complaint
- Be cautious when quoting labor
  - Replacement procedures vary
- Premature failures
  - Pencils, pens, crayons, coins
    - Can cause latent failure
  - Before replacing actuator...
    - Check door moves freely
- **Actuator WARNING**
  - No internal stops - Easily damaged

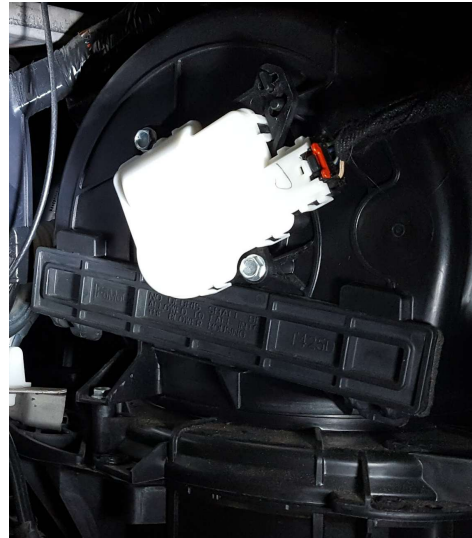

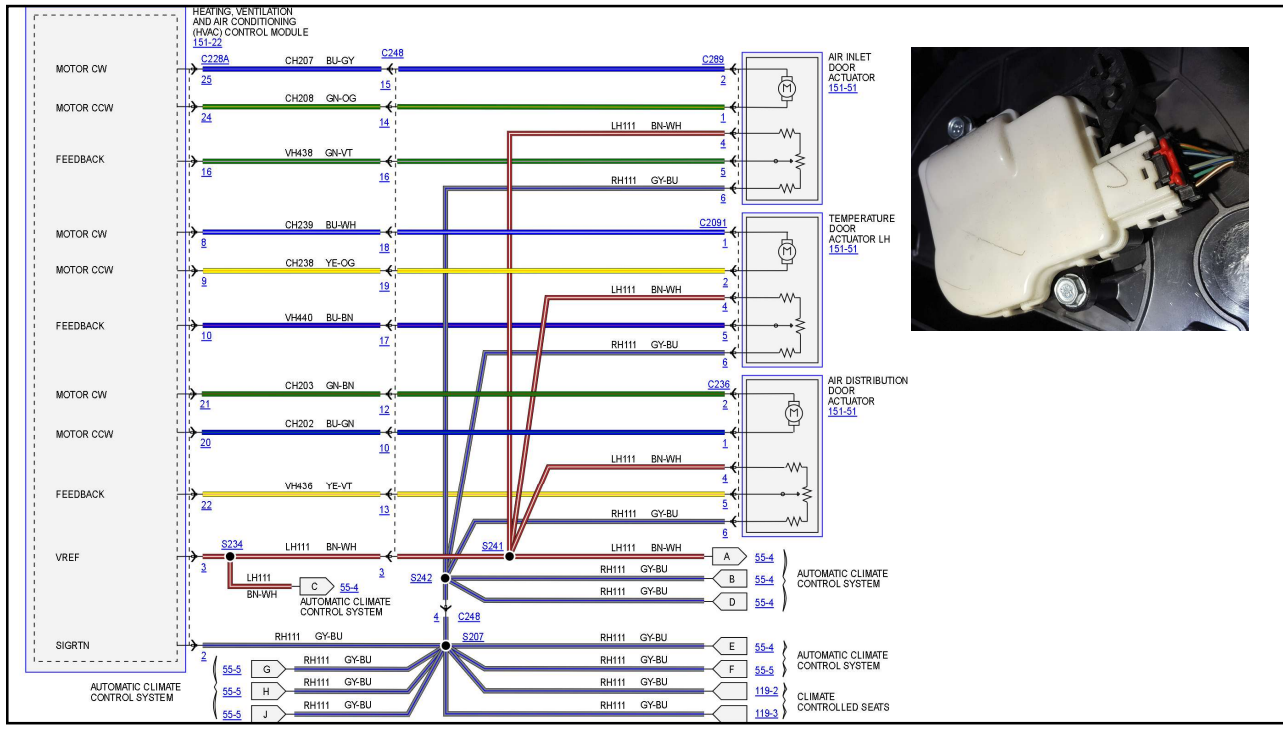

## Schematic Diagram

- A/C Compressor
  - Pin 2 is from A/C Clutch Relay
    - Case Grounded
  - Pin 1 and 3 - from Climate Control Unit
  - 3 Phase High Voltage
    - Wired to A/C Compressor Driver
    - Pin 1 (Lt Blue Wire)
      - 7.5A fuse to Ignition Switch

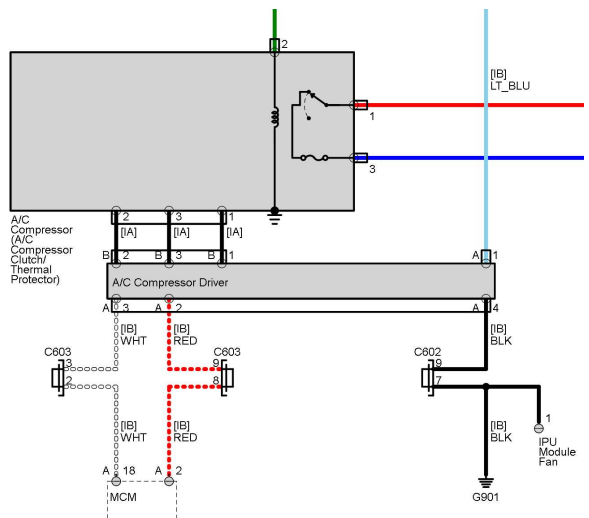

# Honda Hybrid A/C Compressor – Dual Control

All parameter	Name	Value	Range	Unit
<input checked="" type="checkbox"/>	A/C Clutch	OFF		
<input checked="" type="checkbox"/>	A/C Compressor Command	ON		
<input checked="" type="checkbox"/>	A/C Compressor Speed(RPM)	3201		
<input checked="" type="checkbox"/>	A/C Compressor Speed Command(RPM)	3200		



## 2013 Ford Explorer Driver/Operator Complaint

**With A/C On:  
Passenger side air is warmer than Driver side**

## Verification & Validation

- July in NC - 2023
- Ambient Temperature - 81°F
- At Idle in Park
- A/C ON – Set to Low Temp setting
  - Synced
  - Left side center discharge reading
    - Temperature is decreasing 58° F
- Hand test comparison left to right
  - Left side duct is cold
  - **RIGHT side is much warmer**



← 122 →

## Temperature Checks

- Comparison
- Now What?



**58° F**



**88° F**



← 123 →

### Technician Direction

- RRR Machine - Performance Test
- Scan Tool – Check DTCs and analyze data
- Tell customer to put passengers in rear seat!



← 124 →

### RRR Machine Analysis



**Automatic** 02:28:10 07/14/23

HS Press: 142.78 psi	Max HS Press: 164.70 psi
LS Press: 37.24 psi	Min LS Press: 36.86 psi
Temperature: 72.59 °F	
Humidity: 53 %	

Wait for values to stabilize and confirm to capture

✓ ✗



← 125 →

# Scan Tool Time – Vehicle ID

The screenshot shows the 'Vehicle Information' screen in a scan tool. The interface includes a top navigation bar with icons for home, back, settings, print, help, save, and chat. Below the navigation bar, the text 'Ford > Automatic selection' is displayed. On the left, there are two menu options: 'Automatic selection' (highlighted) and 'Manual selection'. The main area displays the following vehicle information:

Vehicle Information	
Vehicle	Explorer
Engine Type	TIVCT
Capacity	3.5L
Transmission	Automatic
Fuel Type	Gasoline
Emission level	Federal Emission
VIN(Vehicle identification number)	1FM5K8F87DGC93772

At the bottom left, the VIN '1FM5K8F87DGC93772' and 'Info:' are shown. At the bottom right, there are 'OK' and 'ESC' buttons. A page number '126' is centered at the bottom.

# DTCs

The screenshot shows the 'Fault Codes(2)' screen in a scan tool. The interface includes a top navigation bar with icons for home, back, settings, print, help, save, and chat. Below the navigation bar, the text 'Ford > Automatic selection > Auto scan > HVAC (Heating Ventilation Air Conditioning) > Trouble codes' is displayed. On the left, there are four menu options: 'ECU information', 'Trouble codes' (highlighted), 'Live data', and 'Active test'. The main area displays a table of fault codes:

DTC	Status	Description	Intelligent diagnostics
B1082:07-0A	CMDTCs	Right Temperature Damper Motor	[Icon]
B1082:13-08	CMDTCs	Right Temperature Damper Motor	[Icon]

At the bottom left, the VIN '1FM5K8F87DGC93772' and 'Info: Ford/Explorer/3.5L/TIVCT' are shown. At the bottom right, there are buttons for 'Intelligent diagnostics', 'Freeze frame', 'Search', 'Erase codes', 'Read codes', and 'ESC'. A page number '127' is centered at the bottom.

## HVAC Data – Alphabetized PIDs

Ford > Automatic selection > Auto scan > HVAC (Heating Ventilation Air Conditioning) > Live data VCM 14.1V

Name	Value	Range	Unit
<input type="checkbox"/> A/C(Air conditioning) Recirculating Servo Position Status	Recirc		
<input type="checkbox"/> Air conditioning clutch	Engaged		
<input type="checkbox"/> Blower Motor Speed	46.27		%
<input type="checkbox"/> Diagnostic Trouble Codes	0		
<input type="checkbox"/> ECU(Electronic control unit) Operating States	Default		
<input checked="" type="checkbox"/> Evaporator Temperature	46.4	[-40.00...212.00]	°F
<input type="checkbox"/> Front Blower Relay	Off		
<input type="checkbox"/> Heated Front Screen	Off		
<input type="checkbox"/> Heated Washer/Jet Mirror	Off		

Cancel All Show Selected Graph Merge To Top Setting Clear Data Freeze Record Review Back

← 128 →

## Left Blend Door Position PIDs

Ford > Automatic selection > Auto scan > HVAC (Heating Ventilation Air Conditioning) > Live data VCM 14.1V

Name	Value	Range	Unit
<input type="checkbox"/> Hevac LIN Power Supply	Off		
<input type="checkbox"/> Ignition Key Status	Key in/Run		
<input type="checkbox"/> Interior Temperature Sensor	73.4		°F
<input checked="" type="checkbox"/> Left Blend Door Position (Cold/Warm/Hot)	Cold		
<input checked="" type="checkbox"/> Left Blend Door Position (%)	1.17		%
<input type="checkbox"/> Left Heated Seat - Climate Control Output	Off		
<input type="checkbox"/> Magnetic valve	Off		
<input type="checkbox"/> Module Supply Voltage	14	[10...15]	V
<input type="checkbox"/> Pollution Sensor and Rear Air Conditioning Power Supply	Off		

Cancel All Show Selected Graph Merge To Top Setting Clear Data Freeze Record Review Back

← 129 →

## Right Blend Door Data PIDs

Ford > Automatic selection > Auto scan > HVAC (Heating Ventilation Air Conditioning) > Live data

Name	Value	Range	Unit
<input type="checkbox"/> Rear Temperature Flap Position	Cold		
<input checked="" type="checkbox"/> Right Blend Door Position (Cold/Warm/Hot)	Hot		
<input checked="" type="checkbox"/> Right Blend Door Position (%)	100	[0...100]	%
<input type="checkbox"/> Right Heated Seat - Climate Control Output	Off		
<input type="checkbox"/> Solar Radiation Sensor (Left)	20	[0...5000]	W
<input type="checkbox"/> Solar Radiation Sensor (Right)	20	[0...5000]	W
<input type="checkbox"/> Unfiltered External Temperature Status	71.6		°F
<input type="checkbox"/> Water pump	Off		
<input type="checkbox"/> air mode actuator	0		%

Buttons: Cancel All, Show Selected, Graph Merge, To Top, Setting, Clear Data, Freeze, Record, Review, Back

← 130 →

## Selected Parameters

Ford V2.31-4.80

Ford > Automatic selection > Auto scan > HVAC (Heating Ventilation Air Conditioning) > Live data

Name	Value	Range	Unit
<input checked="" type="checkbox"/> Left Blend Door Position (Cold/Warm/Hot)	Cold		
<input checked="" type="checkbox"/> Left Blend Door Position (%) (%)	1.17		%
<input checked="" type="checkbox"/> Right Blend Door Position (Cold/Warm/Hot)	Hot		
<input checked="" type="checkbox"/> Right Blend Door Position (%) (%)	100		%

Graphs show data from 03:59 to 04:08. The first graph shows Left Blend Door Position (%) fluctuating around 1.17. The second graph shows Right Blend Door Position (%) constant at 100.

← 131 →

# What do we see?

The screenshot shows a software interface for monitoring HVAC systems. At the top, the breadcrumb path is "Ford > Automatic selection > Auto scan > HVAC (Heating Ventilation Air Conditioning) > Live data". The interface displays five selected items in a table:

Name	Value	Range	Unit
<input checked="" type="checkbox"/> Left Blend Door Position (Cold/Warm/Hot)	Warm		
<input checked="" type="checkbox"/> Left Blend Door Position (%) (%)	33.72		
<input checked="" type="checkbox"/> Right Blend Door Position (Cold/Warm/Hot)	Hot		
<input checked="" type="checkbox"/> Right Blend Door Position (%) (%)	100		

Below the table are two line graphs. The first graph, for the left blend door position, shows a fluctuating line between 0 and 88.62% from 04:30 to 04:48. The second graph, for the right blend door position, shows a constant line at 100% over the same time period. A toolbar at the bottom includes icons for Cancel All, Show all, Graph Merge, To Top, Setting, Clear Data, Freeze, Record, Review, and Back. The Carquest Technical Institute logo is in the bottom left, and a navigation arrow with "132" is at the bottom center.

# What have we Confirmed?

This screenshot shows the same HVAC live data interface as the previous one, but with updated data. The breadcrumb path remains "Ford > Automatic selection > Auto scan > HVAC (Heating Ventilation Air Conditioning) > Live data". The table now shows:

Name	Value	Range	Unit
<input checked="" type="checkbox"/> Left Blend Door Position (Cold/Warm/Hot)	Hot		
<input checked="" type="checkbox"/> Left Blend Door Position (%) (%)	97.25		
<input checked="" type="checkbox"/> Right Blend Door Position (Cold/Warm/Hot)	Hot		
<input checked="" type="checkbox"/> Right Blend Door Position (%) (%)	100		

The first graph now shows the left blend door position increasing from approximately 33% at 05:48 to 97.25% at 06:00. The second graph remains constant at 100%. The toolbar and Carquest Technical Institute logo are identical to the previous screenshot. A navigation arrow with "133" is at the bottom center. A 3D character is standing next to a large red question mark on the right side of the interface.

# Understand the System

- Module Communication
  - Networks
    - HVAC Module
    - Body Control Module
    - Automatic Climate Control System
- Components Involved
  - 5 wire Blend door actuator RH
    - Labor involved to R&R if necessary



# Schematics

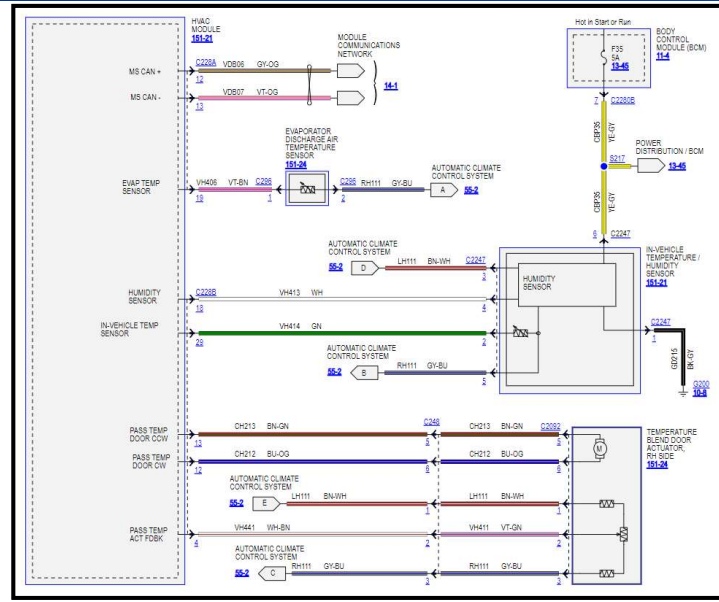

# 2023 Prius Prime - Compressor



- Specifications
  - HV (201.6-AC) Variable Speed
  - Electric Scroll Type
  - Start Up/Max - 3-4 kW
  - Steady State - .8 - 1.5 kW
    - Minimum Load 300-500 watts
- Controlled via Inverter
  - Regulates frequency of AC
    - Meets cooling demand efficiency
  - Discharge 34cc



# EV Compressor Vital Signs

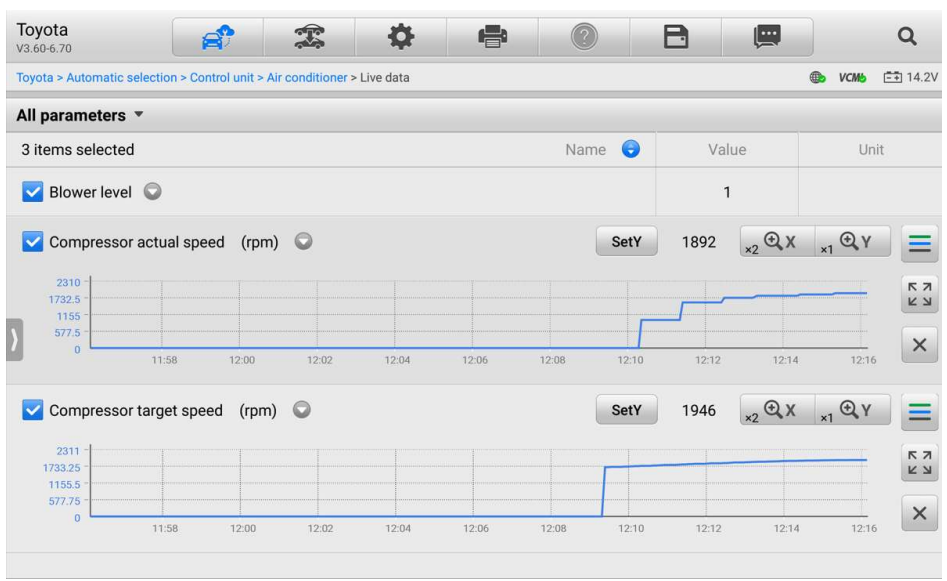

# Recorded View – Merge Graph

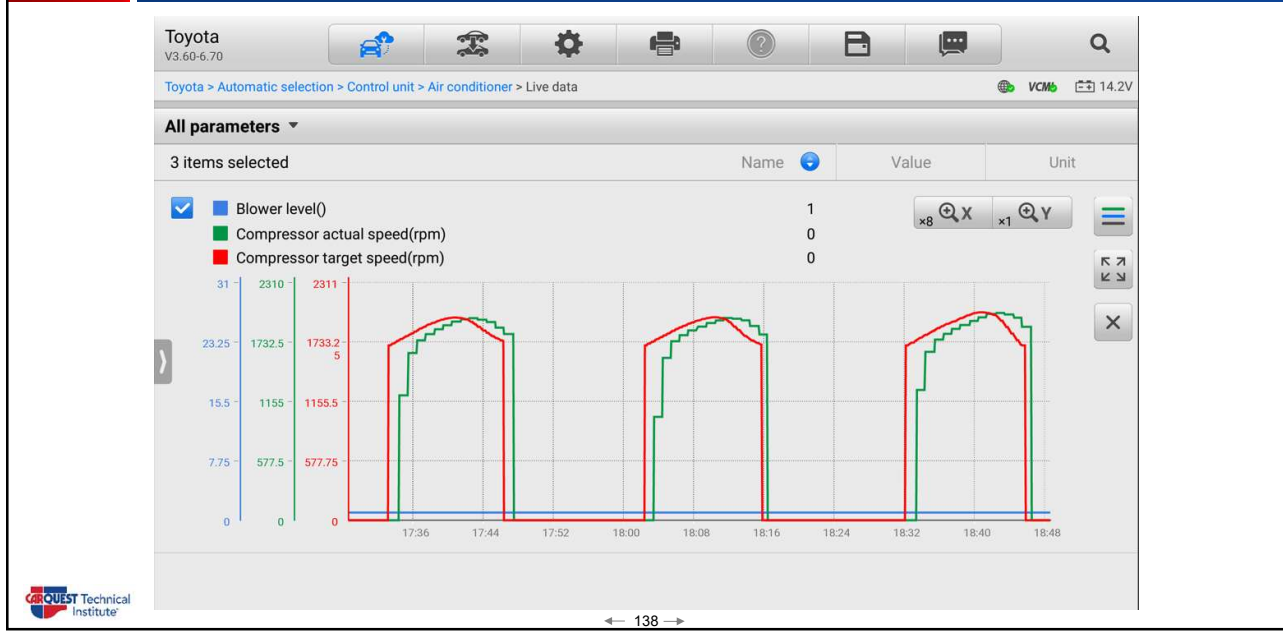

# A/C Compressor Power in Watts

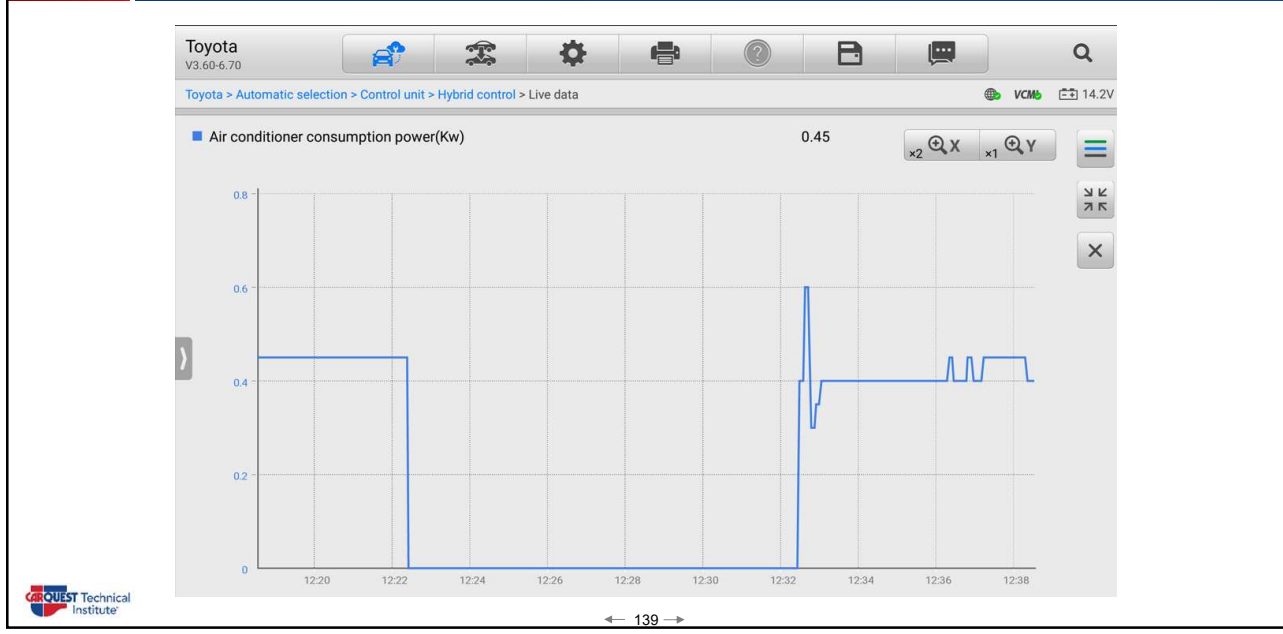

# What are Normal Pressures?

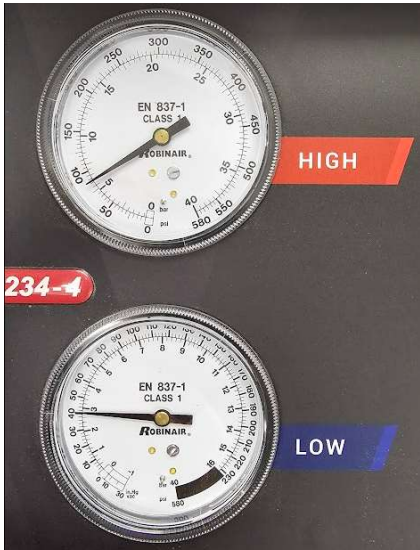

← 140 →

# ctionline.com



Monthly Schedule About Us Help & FAQ

Sign in Sign up

## Training Solutions to Meet Your Needs

Carquest Technical Institute (CTI) provides world-class training to automotive service professionals. CTI work to develop and deliver technical and business management training to shop owners, service advisors, service managers, and technicians. The CTI training advantage combines industry-leading instructors, premium and relevant course content, and training that supports best practices.

We offer In-Person Instructor-Led Training, In-Person Virtual Training via our Virtual Classroom and Self-Paced Online Training solutions to meet your busy schedule and needs.

Search by Course Type:

Virtual Classroom Courses    In-person Instructor Led Courses    Online Self Paced Courses

Virtual Classroom is live, instructor led training delivered via Zoom.

- Learn new skills from CTI's experienced instructors
- See live demos, view shared scope screens, and interact with instructors
- Join from the comfort of your home or wherever you are
- 15+ classes every month

**Virtual Classroom Unlimited for TechNet members**

- Access to all Virtual Classroom courses for all technicians working at your shop.
- Subscription renews monthly. No long-term commitment - cancel anytime.

**\$69.00 USD / month**  
VCU-MONTH-TECHNET

Add to cart

**Virtual Classroom Unlimited**

- Access to all Virtual Classroom courses for all technicians working at your shop.
- Subscription renews monthly. No long-term commitment - cancel anytime.

**\$99.00 USD / month**  
VCU-MONTH

Add to cart

Filter Virtual Classroom Courses

Filter course by keyword

Filter by Instructor

Filter    Clear



12 Results Found

Clear Search



← 146 →