

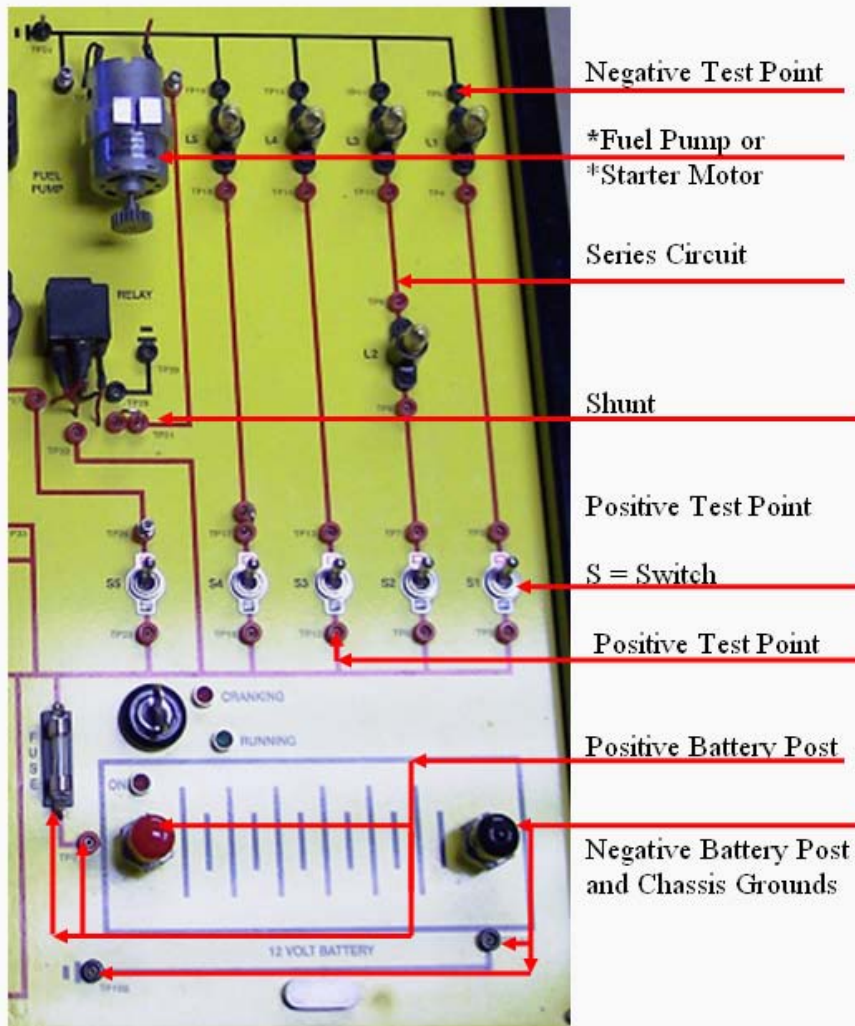

Description of ETrainer testing board



The board is an electrical schematic layout of the systems that are found in vehicles.

**What's required of you / the technician:**

**Ability to use multi-meter and read a schematic**

**You may encounter:**

1. **Parallel circuits**
2. **Series circuits**
3. **Shorts to power and short to ground**
4. **Open circuits**
5. **High resistance**
6. **Bad grounds**
7. **You may encounter shunts in your circuit which you can remove, breaking the circuit open.**
8. **You should be familiar with a multi-meter and how to perform voltage drops, ohm readings and amp readings.**

9. **You must document your work and write down every reading.**

10. **You must follow all directions both written and oral.**

11. **You may encounter multiple problems on some tests.**

**The Electrical 2 test  
uses the TPS circuit**

